



HOT WATER SUPPLY AND RETURN HEADERS PARTS LIST AND ASSEMBLY INSTRUCTIONS

G-Series: Gas-Fired Modular Boilers

Header Parts List

Item	Part No.	Header Package Order Code									
		Number of Modules									
		2	3	4	5	6	7	8	9	10	
1-1/2" Stub Header - 2 stub - 32" C-C (pkgd. separately)	41-2021	2	—	4	2	—	4	2	—	4	
1-1/2" Stub Header - 3 stub - 32" C-C (pkgd. separately)	41-2022	—	2	—	2	4	2	4	6	4	
Flex Joint - 1-1/2" pipe	41-2023	2	4	4	6	8	8	10	12	12	
Flex Joint - 3" pipe	41-1755	4	4	8	8	8	12	12	12	16	
Cast End Cap - 3/4" NPT	41-1780	1	1	1	1	1	1	1	1	1	
Cast End Cap - No tap	41-1753	1	1	1	1	1	1	1	1	1	
Nipple - 1-1/2" x 8"	41-2024	3	4	6	7	8	10	11	12	14	
Nipple - 1-1/2" x 18"	41-2025	1	1	2	2	2	3	3	3	4	
Nipple - 1-1/2" x 4"	43-0904	2	3	4	5	6	7	8	9	10	
Square Nipple - 1-1/2" x 10" T.O.E.	41-2027	1	2	2	3	4	4	5	6	6	
Square Nipple - 1-1/2" x 20" T.O.E.	41-2028	1	2	2	3	4	4	5	6	6	
Union - 1-1/2"	90-2428071	2	2	4	4	4	6	6	6	6	
Tee - 1-1/2"	43-0917	4	6	8	10	12	14	16	18	20	
Bushing - 1-1/2" x 1/4"	41-2036	2	3	4	5	6	7	8	9	10	
Bushing - 1-1/2" x 3/4"	90-2179321	2	3	4	5	6	7	8	9	10	
Installation Instructions	41-1775	1	1	1	1	1	1	1	1	1	

FACTORY SUPPLY AND RETURN HEADER ASSEMBLY — GAS

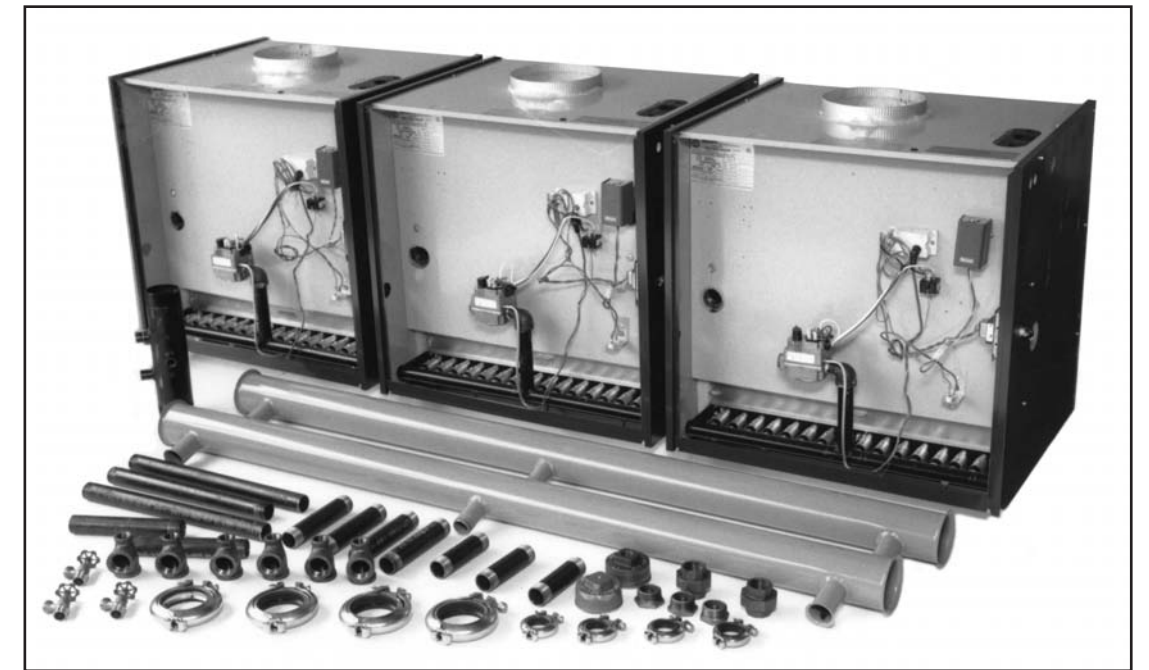
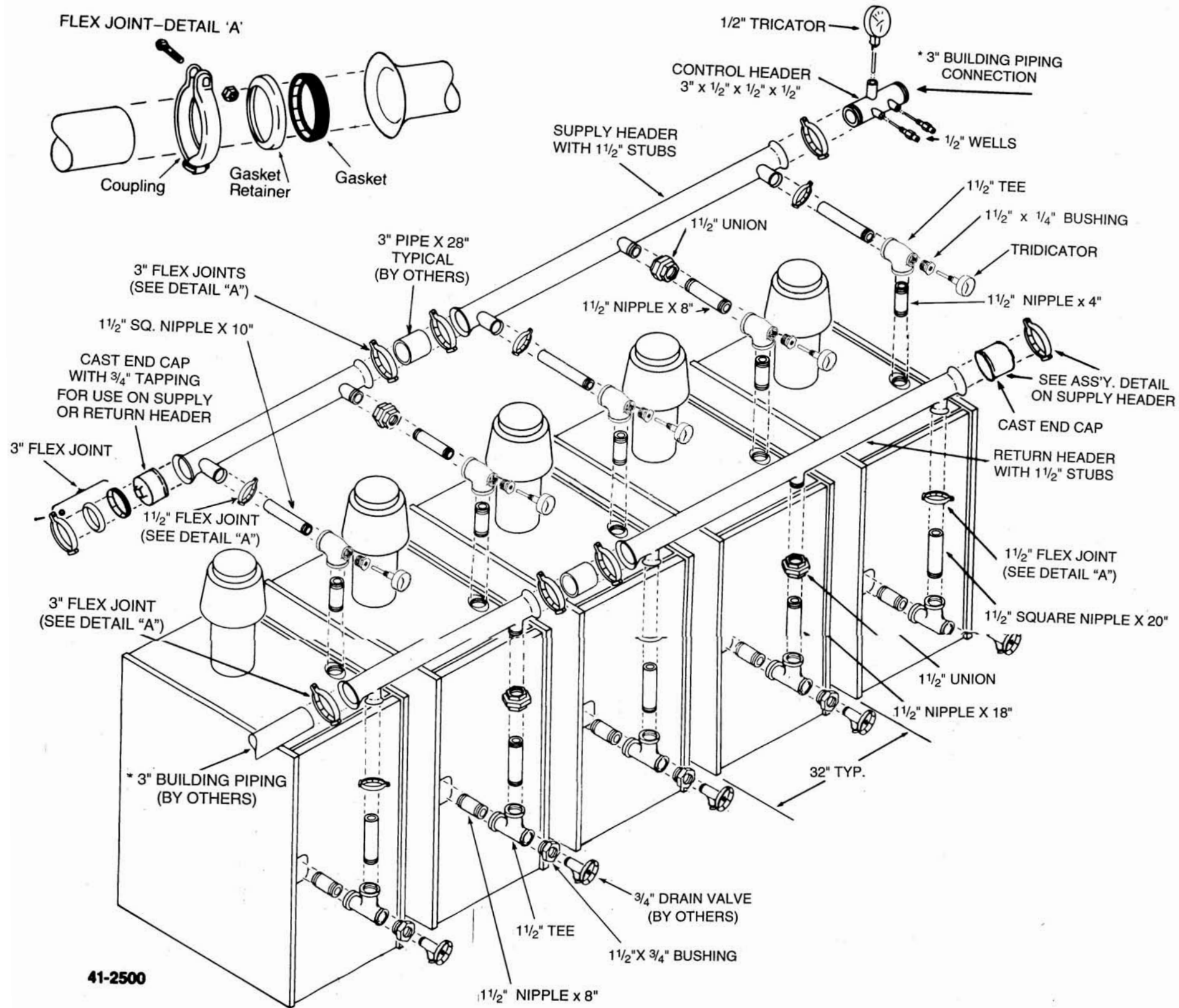

Complete header assembly kit shown for 3 modules.

- Building piping must be rigidly secured so it cannot move where connected to headers.

NOTE:

Shown reverse return. For direct return, header assembly piping connections may be made at the same end of the boiler bank, not as shown.

Some governing agencies do not allow compression type couplings. Consult your local code requirements.

Caravan Flex Joint Assembly Instructions

- Slip the metal retainer on the system piping with the larger diameter side facing the end of the pipe to be joined. The 3" flex joint has a single piece serrated metal retaining ring. This retaining ring should be seated in the recess in the inner diameter of the gasket with its mounting tabs over-lapping slightly where the ring splits. The 1-1/2" flex joint has a 2 piece serrated retaining ring that must be installed in the inner recess of the gasket with its ends butting.

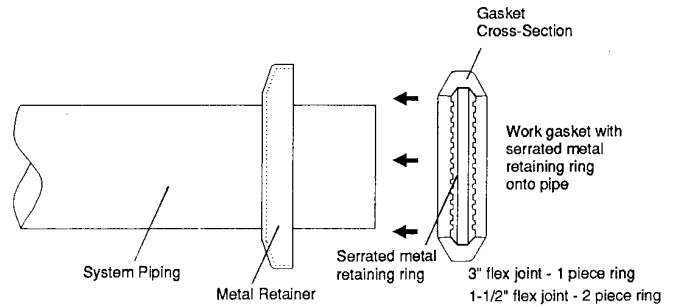

Work the gasket with the serrated metal retaining ring onto the pipe. When installing the gasket be sure the retaining rings seat properly around the pipe. On the 1-1/2" flex joint install the bottom half of the gasket first leaving the other half of the retaining ring free at the top. Then stretch the top of the gasket with the ring over the top of the pipe. **When installing the gaskets if a lubricant is needed, use a soap and water solution only. DO NOT use any oil based lubricants.**

- The gasket must be fully seated in the metal retainer (press together with pliers if necessary). **BE SURE THE GASKET IS SEATED ON AN UNTHREADED SECTION OF PIPE AT LEAST 1" FROM THE END.** Slip the flared end of the Slant/Fin header tube over the pipe and seat against the gasket. Follow illustration a or b for cast end cap or piping.

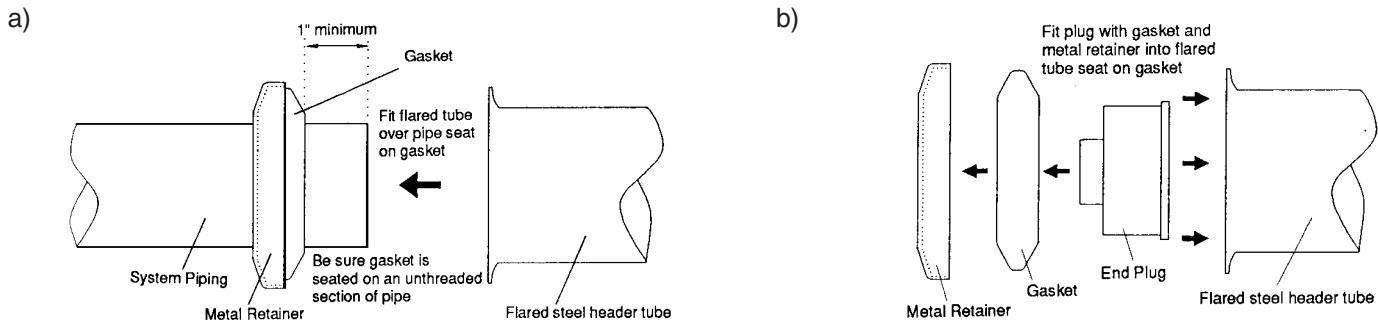

- Open hinged metal clamp and slip over joint. Be sure that the flared end of the steel tubing, the retainer ring and the gasket are enclosed within the clamp.

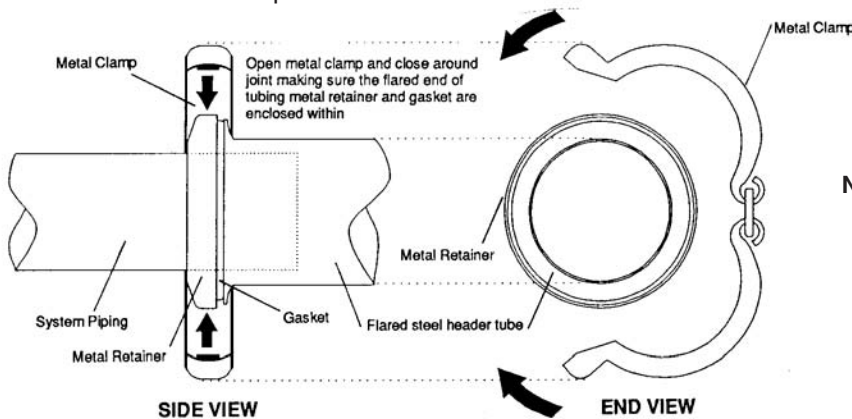

NOTE: Caravan flex joint ratings exceed 100 P.S.I. and 250°F when used in systems using water and water/glycol mix.

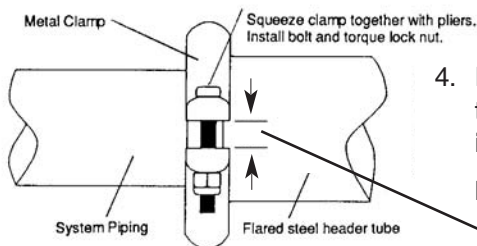

- Install the bolt and lock nut and tighten the lock nut to the following torque values: **1-1/2" flex joint is 140-160 inch-pounds, 3" flex joint is 220-240 inch-pounds.**

NOTE: On 3" schedule 40 pipe, spacing between clamps is approximately 3/8" when properly torqued.

On 1-1/2" schedule 40 pipe, spacing between clamps is approximately 1/4" when properly torqued.