



GAS-FIRED CAST IRON BOILERS FOR NATURAL AND L.P. PROPANE GASES

GALAXY

MODELS GG-75 THROUGH GG-375 — HOT WATER
MODELS GX-100 THROUGH GX-300 — LOW PRESSURE STEAM & HOT WATER

AND

RELIANT 100 SERIES

MODELS 100-A-35 THROUGH
100-A-180 — HOT WATER

INSTALLATION AND OPERATING INSTRUCTIONS

CONTENTS	PAGE
Ratings, Dimensions, Data	2,3
Installation Requirements:	
Boiler Location	4
Boiler Foundation	4
Minimum Clearance	4
Chimney Requirements.....	4
Vent Piping	5
Gas Piping	5
Electrical Controls and Wiring.....	5
Boiler Room Air Supply and Ventilation.....	5
Draft Hood Installation	5
Piping at Boiler—Water Boilers	6
Steam Boilers—Piping and Low Water Cut Off	6,7
Vent Damper.....	8,9
Operating Instructions:	
Filling and Venting Water Systems.....	10
Initial Start, Safety & Lighting Instructions	10-14
Burner Adjustment, Checking Gas Input.....	14
Controls, Safety Check	14,15
Blowing Off a Steam Boiler.....	16
Care and Maintenance	17
Safety Check for Control System.....	17
Protection From Freezing	17
Water Treatment	17
Wiring Diagrams	18,19,21-25
Sequence of Operations	19,20
Pump or Valve Zoning—Water Boilers.....	26
Trouble Shooting Guide	27
Piping a Heating and Cooling System	28
Replacement Parts	28

IMPORTANT
**READ ALL OF THE FOLLOWING
WARNINGS AND STATEMENTS
BEFORE READING THE
INSTALLATION INSTRUCTIONS**

WARNING
LIQUEFIED PETROLEUM (L.P.)
PROPANE FIRED GAS BOILERS

Installation location ONLY as permitted in paragraph entitled "LIQUEFIED PETROLEUM (L.P.) PROPANE GAS FIRED BOILER LOCATION" on page 4 of this instruction book.

The above warning does not apply to NATURAL gas fired boilers.

The installation must conform to the requirements of the authority having jurisdiction or, in the absence of such requirements, to the National Fuel Gas Code, ANSI Z223.1-latest edition. The installation must also conform to the additional requirements in this Slant/Fin Instruction Book.

In addition, where required by the authority having jurisdiction, the installation must conform to American Society of Mechanical Engineers Safety Code for Controls and Safety Devices for Automatically Fired Boilers, No. CSD-1.

This manual must be left with owner and should be hung on or adjacent to the boiler for reference.



VIEWS — DIMENSIONS — DATA

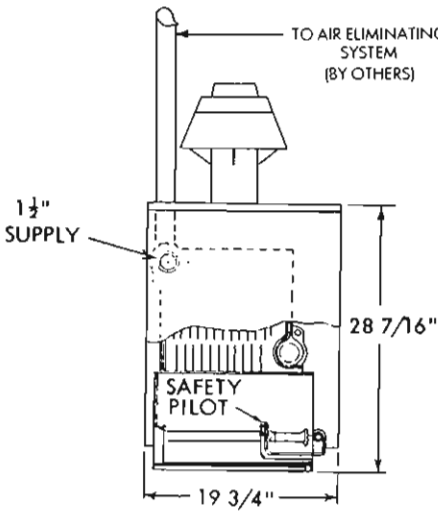

Fig. 1—Left End View

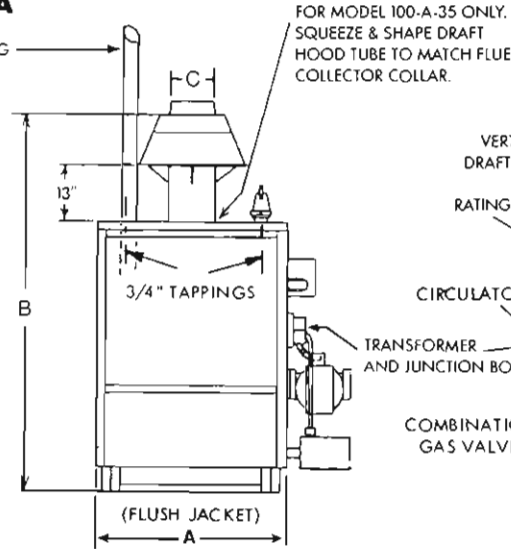

Fig. 2—Front View

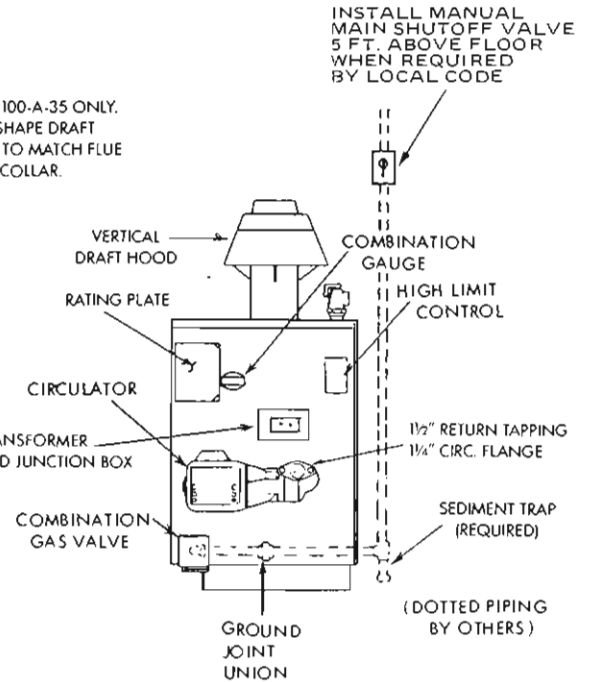

Fig. 3—Right End View

NOTE: Height Dimension increases by 1-3/4" when combustible floor kit is used.

BOILER MODEL	No. of Sections	Dimensions (Inches)			Approximate Total Weight Full of Water (Lb.)	Size of Gas Line Connection to Boiler (Inches)	
		A	B	C		Natural	Propane
100-A-35	2	8 1/8	47 1/2	2 1/4 x 5 oval (4)	190	1/2"	1/2"
100-A-60	3	11 1/8	47 1/2	4	250	1/2"	1/2"
100-A-90	4	14 1/8	48 1/4	5	310	1/2"	1/2"
100-A-120	5	17 1/8	48 1/4	5	365	1/2"	1/2"
100-A-150	6	20 1/8	48 7/8	6	425	1/2"	1/2"
100-A-180	7	23 1/8	48 7/8	6	490	1/2"	1/2"

CHIMNEY RECOMMENDATIONS

HEIGHT: 15 ft (minimum) from draft hood skirt to top of chimney.

INSIDE DIAMETER: Same as Dimension C (or larger).

NOTE: Larger chimney may be required if two or more boilers or a boiler and another appliance are vented to a single chimney.

BOILER MODELS	GAS TYPE	100 SERIES ORIFICE SIZE AT SEA LEVEL	EQUIVALENT ORIFICE SIZES AT HIGH ALTITUDES INCLUDES 4% REDUCTION FOR EACH 1000 FEET								
			ELEVATION—FEET								
			2000	3000	4000	5000	6000	7000	8000	9000	10000
100-A-35	NATURAL	33	35	36	36	37	37	38	39	40	41
100-A-35	PROPANE	51	52	52	52	53	53	53	54	54	54
100-A-60 THRU 100-A-150	NATURAL	37	38	39	40	41	42	42	43	43	43
100-A-60 THRU 100-A-180	PROPANE	53	53	54	54	54	54	55	55	55	55
100-A-180	NATURAL	38	38	39	40	41	42	42	43	43	43

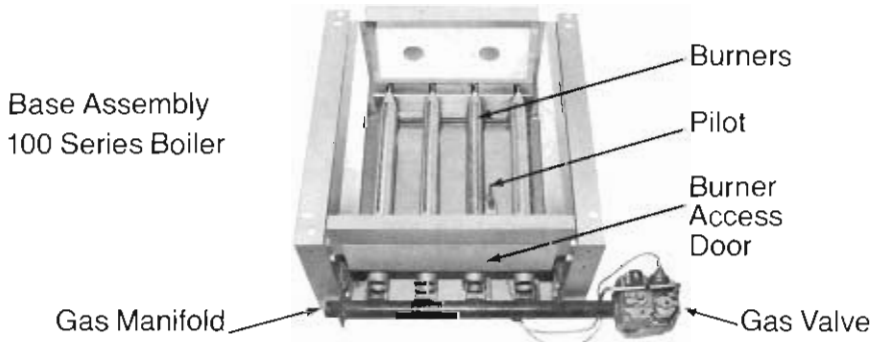

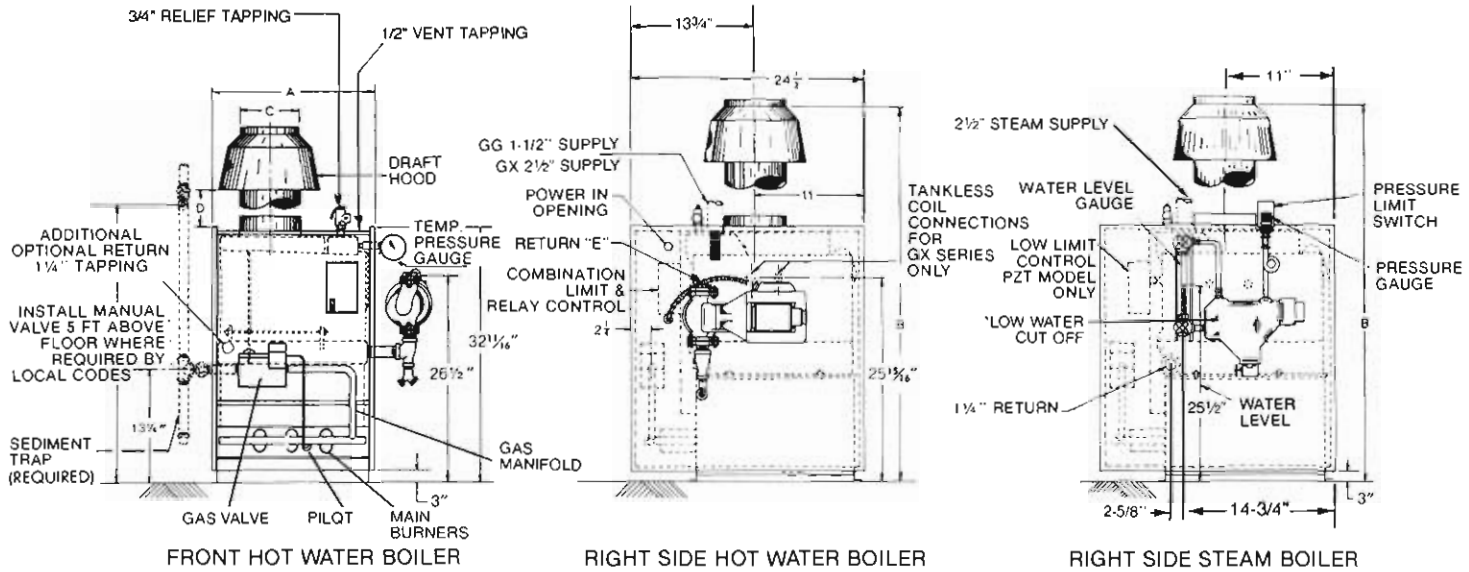

NOTE: 1. When mounting boiler on a raised slab, make sure slab extends at least 2" beyond boiler jacket on all sides.
 2. Height dimension increases by 1" when combustible floor kit is used.

* Probe type low water cut off for Steam Boilers without provision for Tankless Heater.
 Float type low water cut off for Steam Boilers with provision for Tankless Heater or with Tankless Heater.

TABLE 1

DIMENSION INCHES	MODEL GG SERIES (Hot Water)												
	GG-75	GG-100	GG-125	GG-150	GG-175	GG-200	GG-225	GG-250	GG-275	GG-300	GG-325	GG-350	GG-375
"A"	13-3/16	13-3/16	13-3/16	16-9/16	16-9/16	19-15/16	19-15/16	23-5/16	23-5/16	26-11/16	26-11/16	30-1/16	30-1/16
"B"	46-3/8	53-1/4	53-1/4	53-1/4	53-1/4	57-1/2	57-1/2	59-5/8	59-5/8	59-5/8	59-5/8	66-1-8	66-1-8
"C"	5	6	6	6	6	7	7	8	8	8	8	9	9
"D"	6-3/4	13	13	13	13	16	16	17	17	17	17	22-1-2	22-1-2
"E"	1-1/4	1-1/4	1-1/4	1-1/4	1-1/4	1-1/4	1-1/4	1-1/2	1-1/2	1-1/2	1-1/2	1-1/2	1-1/2
Gas Connection Nat./Prop.	1/2 1/2	1/2 1/2	1/2 1/2	1/2 1/2	1/2 1/2	1/2 1/2	1/2 1/2	1/2 1/2	3/4 1/2 or 3/4	3/4 1/2 or 3/4	3/4 1/2 or 3/4	3/4 1/2 or 3/4	3/4 1/2 or 3/4

DIMENSIONS INCHES	MODEL GX SERIES											
	HOT WATER WITH TANKLESS HEATER — LOW PRESSURE STEAM WITH OPTIONAL TANKLESS HEATER											
	GXH-105 GX-105	GXH-125 GX-125	GXH-150 GX-150	GXH-170 GX-175	GXH-190 GX-200	GXH-210 GX-225	GXH-230 GX-250	GXH-250 GX-275	GXH-275	GXH-300 GX-300		
A	16-9/16	16-9/16	19-15/16	19-15/16	19-15/16	23-5/16	23-5/16	26-11/16	26-11/16	26-11/16		
B	46-5/8	53-1/4	53-1/4	55-1/2	55-1/2	55-1/2	56-5/8	56-5/8	62-5/8	56-5/8	67-5/8	
C	5	6	6	7	7	7	7 8	7 8	7	8		
D	7	13	13	14	14	14	14	14	14	20	14	25
E	1-1/4	1-1/4	1-1/4	1-1/4	1-1/4	1-1/4	1-1/2	1-1/2	1-1/2	1-1/2	1-1/2	1-1/2
Gas Connection (Nat./Prop.)	1/2 1/2	1/2 1/2	1/2 1/2	1/2 1/2	1/2 1/2	1/2 1/2	1/2 1/2	1/2 1/2	3/4 1/2 or 3/4	3/4 1/2 or 3/4	3/4 1/2 or 3/4	3/4 1/2 or 3/4

CHIMNEY RECOMMENDATIONS

HEIGHT: 15 ft. (minimum) from draft hood skirt to top of chimney. INSIDE DIAMETER: Same as Dimension C (or larger).
 NOTE: Larger chimney may be required if two or more boilers or a boiler and another appliance are vented to a single chimney.

	ORIFICE SIZE AT SEA LEVEL GALAXY	EQUIVALENT ORIFICE SIZES AT HIGH ALTITUDES INCLUDES 4% REDUCTION FOR EACH 1000 FEET									
		ELEVATION — FEET									
		2000	3000	4000	5000	6000	7000	8000	9000	10000	
GG/GX	(Natural)	41	42	42	42	43	43	44	44	45	46
	(Propane)	54	54	55	55	55	55	55	56	56	56
GXH-105 THRU 275	(Natural)	43	44	44	44	45	45	46	46	47	48
	(Propane)	55	55	56	56	56	56	56	57	57	57
GXH-300	(Natural)	42	43	43	43	44	44	45	45	46	47
	(Propane)	54	54	55	55	55	55	55	56	56	56

INSTALLATION REQUIREMENTS

The installation must conform to the requirements of the authority having jurisdiction or, in the absence of such requirements, to the National Fuel Gas Code, ANSI Z223.1-latest edition.

This installation must also conform to the additional requirements in this Slant/Fin instruction book.

NATURAL GAS FIRED BOILER LOCATION—

Provide a level, solid foundation for the boiler. Location should be as near the chimney as possible so that the flue pipe from boiler to chimney is short and direct.

WARNING

LIQUEFIED PETROLEUM (L.P.) PROPANE FIRED GAS BOILER LOCATION

The following precautions are cited by the 1985 UNIFORM MECHANICAL CODE, section 504, paragraph (f):

"LPG Appliances. Liquefied petroleum gas-burning appliances shall not be installed in a pit, basement or similar location where heavier-than-air gas might collect. Appliances so fueled shall not be installed in an above-grade under-floor space or basement unless such location is provided with an approved means for removal of unburned gas."

Consult Chapter 11 of the 1985 UNIFORM MECHANICAL CODE for design criteria of the "approved" means for removal of unburned gas.

Liquefied Petroleum (LP) propane gas is *heavier than air*. Therefore, propane boilers, piping, valves must NOT be installed in locations where propane leaking from defective equipment and piping will "pool" in a basement or other space below the leak.

A spark or flame from the boiler or other source may ignite the accumulated propane gas causing an explosion or fire.

Provide a level, solid foundation for the boiler. Location should be as near the chimney as possible so that the flue pipe from boiler to chimney is short and direct.

BOILER FOUNDATION—

- Provide a solid, level foundation, capable of supporting the weight of the boiler filled with water, and extending at least 2" past the jacket on all sides. See dimensions of boilers, pages 2 & 3.
- For installation on non-combustible floors only.*
- If boiler is to be located over buried conduit containing electric wires or telephone cables, consult local codes or the National Board of Fire Underwriters for specific requirements.

* For installation on combustible floors only when equipped with Combustible Floor Kit Part No. Printed on the boiler rating plate. The boiler must not be installed on carpeting.

CHIMNEY REQUIREMENTS—

- A vitreous tile lined chimney of the minimum diameter shown on pages 2 & 3 (or its rectangular equivalent) or a Type 'B' vent is recommended. Local codes apply.
- Inspect for proper and tight construction. Any restrictions or obstructions must be removed. An existing chimney may require cleaning.
- Chimney or vent must extend at least 3 feet above its passage through a roof and at least 2 feet above any ridge within 10 feet of the chimney.

MINIMUM CLEARANCES FROM COMBUSTIBLE CONSTRUCTION—

Minimum boiler clearances shall be as follows:

A.

GALAXY GG SERIES			
MODELS GG-75 THRU GG-225.		MODELS GG-250 THRU GG-375.	
MINIMUM CLEARANCE FOR COMBUSTIBLE CONSTRUCTION.		MINIMUM CLEARANCE FOR COMBUSTIBLE CONSTRUCTION.	
MINIMUM CLOSET CLEARANCE.		MINIMUM ALCOVE CLEARANCE.	
Front	6"	Front	Alcove
Rear	6"	Rear	6"
Left Side	6"	Left Side	6"
Right Side	18"	Right Side	18"
Top	36"	Top	36"
Flue Connector	6"	Flue Connector	6"
Type 'B' Vent	1"	Type 'B' Vent	1"

GALAXY GX SERIES			
MODELS GX-100 THRU GX-200; GXH-105 THRU GXH-275		MODELS GX-225 THRU GX-300; GXH-300.	
MINIMUM CLEARANCE FOR COMBUSTIBLE CONSTRUCTION.		MINIMUM CLEARANCE FOR COMBUSTIBLE CONSTRUCTION.	
MINIMUM CLOSET CLEARANCE.		MINIMUM ALCOVE CLEARANCE.	
Front	6"	Front	Alcove
Rear	6"	Rear	6"
Left Side	6"	Left Side	6"
Right Side	18"	Right Side	18"
Top	36"	Top	36"
Flue Connector	6"	Flue Connector	6"
Type 'B' Vent	1"	Type 'B' Vent	1"

100-A SERIES	
MINIMUM CLEARANCE FOR COMBUSTIBLE CONSTRUCTION.	
MINIMUM ALCOVE AND CLOSET CLEARANCE.	
Front	6"
Rear	6"
Left Side	6"
Right Side	18"
Top	36"
Flue Connector	6"

B. All minimum clearances shown above must be met. This may result in increased values of some minimum clearances in order to maintain the minimum clearances of others.

C. Clearance from steam and hot water pipes shall be 1". **

** At points where hot water or steam pipes emerge from a floor, wall or ceiling, the clearance at the opening through the finish floor boards or wall or ceiling boards may be not less than 1/2". Each such opening shall be covered with a plate of uncombustible material.

SAFETY—

KEEP THE BOILER AREA CLEAR AND FREE FROM COMBUSTIBLE MATERIALS, GASOLINE AND OTHER FLAMMABLE VAPORS AND LIQUIDS.

VENT PIPING—

- A. Vent piping installation must be in accordance with ANSI Z223.1 (latest edition), National Fuel Gas Code, Part 7, Venting of Equipment. Other local codes may also apply and must be followed.
- B. Boiler vent pipe must be the full diameter of the boiler draft hood outlet. See dimensions, pages 2 and 3. If a vent damper is added, its diameter must be equal to the hood outlet and must be located past the hood outlet. See installation instructions furnished with vent damper and in the section "Vent Damper Installation" of this instruction book.
- C. If more than one appliance vents into a common breeching, the area of the breeching must be equal to the area of the largest vent plus 50% of the area of the additional vent areas. Vent connectors serving appliances vented by natural draft shall not be connected into any portion of mechanical draft systems operating under positive pressure. Horizontal breeching or vent pipe should be as high as possible, consistent with codes, so that vertical vents from appliances will have a high rise above draft diverter openings. All horizontal runs must slope upwards not less than 1/4 inch per foot of run. Horizontal portions of the venting system must be supported to prevent sagging by securing each joint with metal screws and by providing hangers spaced no greater than 5 feet apart.
- D. Vent or breeching into chimney should not be inserted past the inside wall of the chimney liner.
- E. All venting means should be inspected frequently. See Care and Maintenance and separate Owners Information Manual.

GAS PIPING—

- A. Local installation codes apply. The pipe joint compound used on threads must be resistant to the action of liquified petroleum gases.
- B. The gas supply line to the boiler should be run directly from the meter. See pages 2 & 3 for location of union and manual main shutoff valve that may be specified locally.
- C. The boiler and its gas connection must be leak tested before placing the boiler in operation. Use liquid soap solution for all gas leak testing. Do not use open flame.

This boiler and its individual shutoff valve must be disconnected from the gas supply piping system during any pressure testing of that system at test pressures in excess of 1/2 PSIG.

This boiler must be isolated from the gas supply piping system

by closing its individual manual shutoff valve during any pressure testing of the gas supply piping system at test pressures equal to or less than 1/2 PSIG.

- D. All gas piping used should be inspected thoroughly for cleanliness before makeup. A sediment trap must be provided, as illustrated on pages 2 & 3.
- E. The minimum gas supply pressure for the gas used is shown on the boiler rating plate. Table A, may be used to determine required pipe sizes for natural gas.

ELECTRICAL CONTROLS AND WIRING—

- A. The electrical power to the boiler must be on a separately fused and live circuit.
- B. If an external electrical source is utilized, the boiler, when installed, must be electrically grounded in accordance with the requirements of the authority having jurisdiction or, in absence of such requirements, with the National Electrical Code, ANSI/NFPA No. 70-latest edition.
- C. Basic control wiring diagrams are given on page 18 through 25. Other control systems may be factory supplied: see User's Information Manual and Instructions packed with control system supplied.
- D. After placing the boiler in operation, the safety shutoff device must be tested. See page 14 safety check.

BOILER ROOM AIR SUPPLY AND VENTILATION

An ample supply of air is required to obtain combustion and ventilation. ALL AIR MUST COME FROM OUTSIDE, directly through wall openings to the boiler or through unsealed openings around windows, doors, etc. in the whole building. When buildings are insulated, caulked and weather-stripped, now or later on, direct opening to outside may be required and should be provided. If the boiler is not on an outside wall, air may be ducted to it from outside wall openings.

The National Fuel Gas Code, ANSI Z223.1-latest edition specifies openings for air under various conditions. Local codes may specify minimum opening sizes and locations. The following recommendation applies to buildings of energy-saving construction, fully caulked and weather stripped:

Provide one GRILLED opening near the floor and one near the ceiling on an outside wall near the boiler (or duct from such openings to the boiler), EACH opening to be a minimum of one square inch per 2000 Btuh input to ALL APPLIANCES in the area. For a total appliance input of 200,000 Btuh, each opening will be 100 square inches. A grilled opening 10" x 10" has 100 square inches of area. If fly screen must be used over openings, double the area and inspect and clean the screen frequently.

Openings must never be reduced or closed. If doors or windows are used for air supply, they must be locked open. Protect against closure of openings by snow and debris. Inspect frequently.

No mechanical draft exhaust or supply fans are to be used in or near the boiler area.

The flow of combustion and ventilating air to the boiler must not be obstructed.

DRAFT HOOD—

The draft hood supplied is part of the listed boiler assembly. Do not alter the hood. See dimensions, pages 2 & 3.

Attach the hood to the boiler flue outlet. Connect flue pipe full size of hood outlet. If a vent damper is added, it must be installed on the outlet side of the hood. See Vent Piping, above.

LENGTH OF PIPE FT.	TABLE A. GAS FLOW IN PIPING— CU. FT. PER HR. (At pressure drop of 0.3 in. water. Specific gravity = 0.60)				
	IRON PIPE SIZE (IPS) INCHES				
	1/2	3/4	1	1 1/4	1 1/2
10	132	278	520	1,050	1,600
20	92	190	350	730	1,100
30	73	152	285	590	890
40	63	130	245	500	760
50	56	115	215	440	670
60	50	105	195	400	610
70	46	96	180	370	560
80	43	90	170	350	530
90	40	84	160	320	490
100	38	79	150	305	460

PIPING AT BOILER — WATER PIPING

I. CIRCULATING SYSTEMS

A. Packaged water boilers are equipped with a water circulating pump, mounted to return the water into the boiler. For some installations, the pump should be on the supply main. See PUMP LOCATION, below.

II. AIR CONTROL SYSTEM

A. DIAPHRAGM-TYPE COMPRESSION TANKS are used to control system pressure in an AIR ELIMINATING SYSTEM: an automatic air vent is used to REMOVE air from the system water. See illustration. If system pressure needs further control, add an additional tank or install a larger capacity tank. Locate the tank near the boiler, as illustrated. An automatic air vent should be installed in the top of the boiler. See illustration.

B. PUMP LOCATION — Locating low-head pump(s) on return to boiler is acceptable for smaller boiler sizes in residences of one or two stories. The alternate pump location shown in illustration is required in large, multi-story building installations, especially when high-head pumps are used. The compression tank must be at the boiler or between boiler and supply main pump(s).

C. On a hot water boiler installed above radiation level, the boiler must be provided with a low water cut off device at the time of installation by the installer.

Flow Control Valve: When domestic hot water tankless heater is used, a flow control valve should be installed in supply piping to heating system, as shown in illustration.

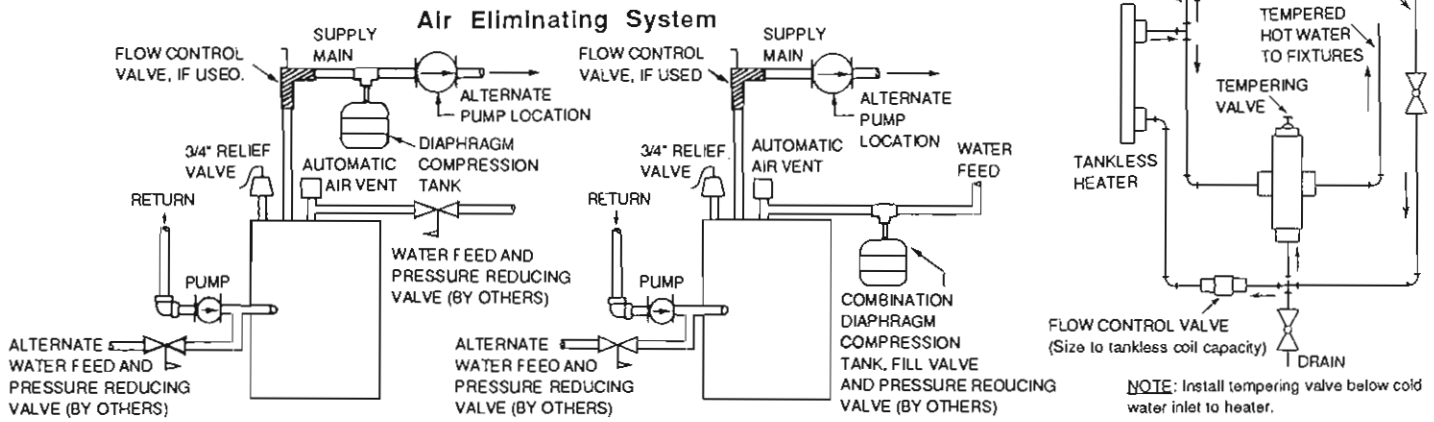

INSTALLATION INSTRUCTIONS FOR GX LOW PRESSURE STEAM BOILERS EQUIPPED WITH TANKLESS OR PROVISION FOR TANKLESS AND McDONNELL & MILLER TYPE 67 LOW WATER CUT OFF.

STEAM CONTROLS ASSEMBLY AND INSTALLATION INSTRUCTIONS

Steam kit components for Galaxy packaged models are packed as follows:

- A. 1. Low water cut off control
2. Fittings
3. L.W.C.O. instruction sheet
- B. 1. Pressure gauge
2. High pressure limit control
3. Water level gauge
4. Fittings
5. Instruction sheet and assembly drawing
6. Steam safety valve and 3/4" street coupling
7. Drain cock
8. Thermostat

Assemble above components exactly as shown in steam controls assembly. Two 1/2" tapings are on right side of boiler for this assembly. Two holes are pre-punched in jackets. For convenience, start assembling in the following steps:

1. Install 1/2" x 5-1/2" brass nipple onto tee of L.W.C.O.
2. Mount 1/2" x 5-1/2" brass nipple into lower boiler tapping by rotating low water cut-off.
3. Assemble 90° brass tubing to tee adapter and L.W.C.O.
4. Install 1/2" x 6" brass nipple and 1/2" x 5/8" adapter tee in upper boiler tapping.
5. Install syphon, high pressure limit and pressure gauge with 1/4" brass fittings.
6. Install water level gauge (without glass) and its fittings.
7. Install water level glass, and mark the glass 25-1/2" from the bottom of the steel boiler base for the water level.

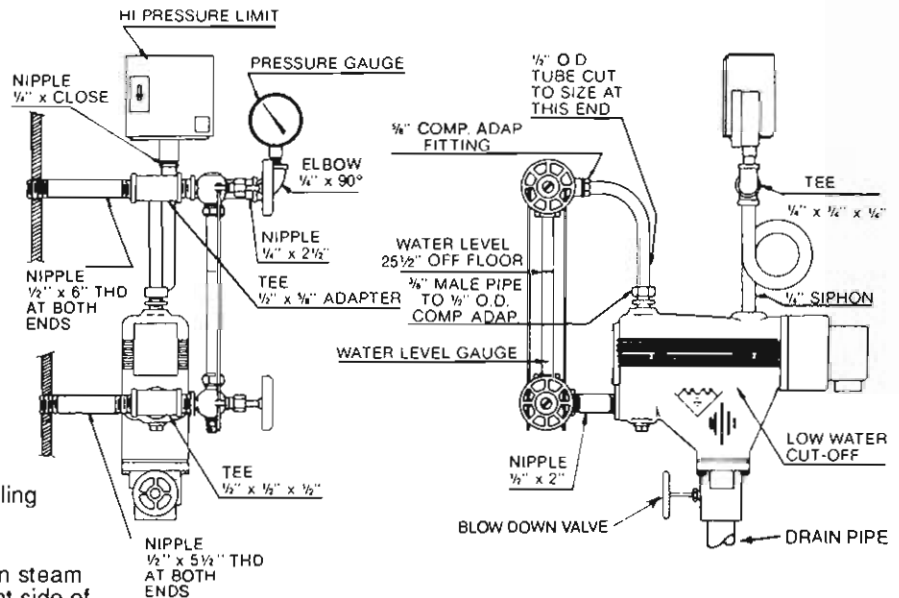

SPECIAL FLUSHING INSTRUCTIONS

Installation of new boiler may break loose a heavy accumulation of sediment and scale from old piping and radiators. It is extremely important to blow down your McDonnell Cut-off 67 more frequently the first week.

First week — 3 times

Thereafter — at least once a week

* Exception: McDonnell Cut-off 42A must be blown down daily.

See 'CARE & MAINTENANCE' for instructions.

(The steel boiler base should not be confused with a combustible floor kit when making the 25-1/2" measurement.)

8. Drain cock will be installed in return tee at the lower right side of casting.
9. Safety valve and 3/4" street coupling should be installed in 3/4" tapping on top of boiler.

VENT DAMPER INSTALLATION

The vent damper referred to in the following instructions is the Slant/Fin Corporation Model SP52 or SK19 Vent Damper.

- I. This device is design certified by A.G.A. for use ONLY on specific Slant/Fin Corp. gas boiler models. These boilers must also be equipped with a plate which states that the boiler may be used with a Slant/Fin Corp. automatic vent damper device and indicates the proper vent damper model number. This device cannot be used with millivolt ignition system.
- II. A. INSTALLATION INSTRUCTIONS BEFORE YOU START TO INSTALL
 1. Read this installation manual, the "DANGER" plate attached to the top of the boiler, the "WARNING" on the wiring diagrams, vent damper carton and operator cover, and the installation instructions packed with the Slant/Fin vent damper.
 2. Perform pre-installation inspection as required by ANSI specification Z21.66.
 3. Turn off all electrical power, gas supply and wait for system to cool.
 4. Select a proper, convenient location (see figure 1 and 2).
 5. Carefully unpack the unit. The damper is spring loaded, and should drive to an open position when removed from packing. DO NOT FORCE IT CLOSED! Forcing the damper may damage the gear train and void the warranty.

WARNING—DANGER

Once you have begun vent damper installation procedure, do not restore electric power and gas supply until installation and inspection have been completed (in order to prevent the main burners from operating). Do not operate the boiler until the vent damper wiring harness "RECEPTACLE B" is plugged into "MALE PLUG" (as described in the installation instructions), and the vent damper installation and check-out procedures have been completed. Failure to observe this warning may create a hazardous condition that could cause an explosion or carbon monoxide poisoning.

- B. 1. This device must be installed after the appliance draft hood (between the draft hood outlet and the connector to the outdoor chimney or vent) as close to the draft hood as practicable, and without modification of the draft hood or the damper. (See figure 1 and 2.)
2. The inlet size of the vent damper must be the same nominal trade size as the outlet of the draft hood.
3. This device must be located in a venting system or section of a venting system so that it serves only the single appliance for which it is installed. (See Fig.5).
4. Clearances of not less than 6 inches (152MM) must be maintained from combustible materials, with provisions for access for service.

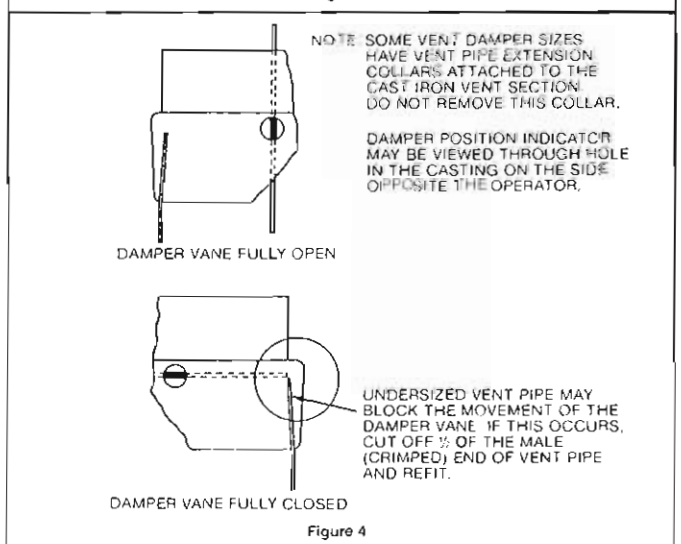
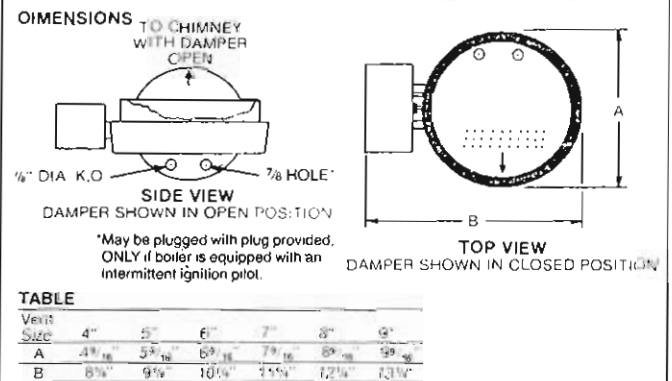
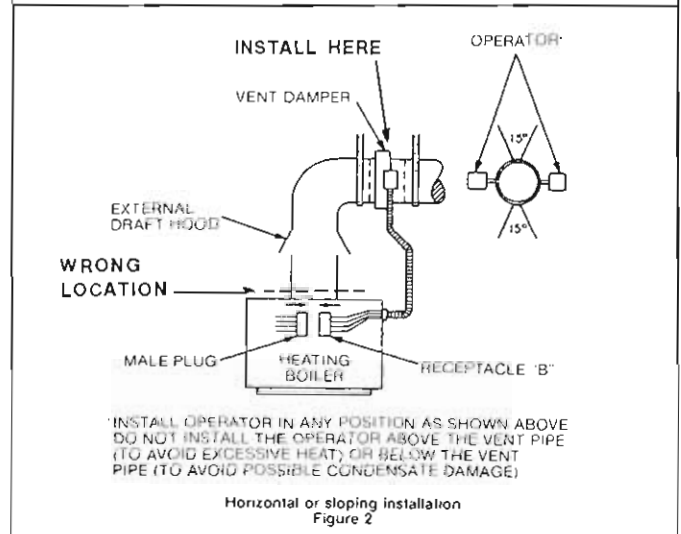
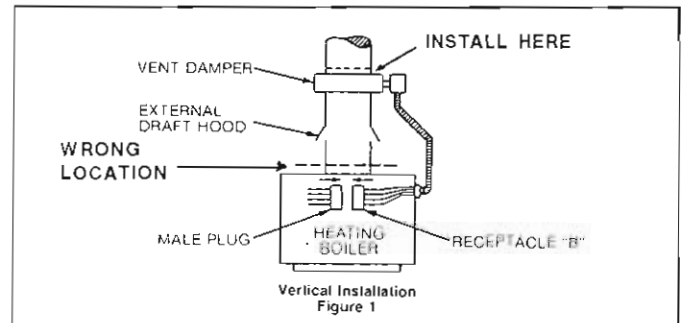

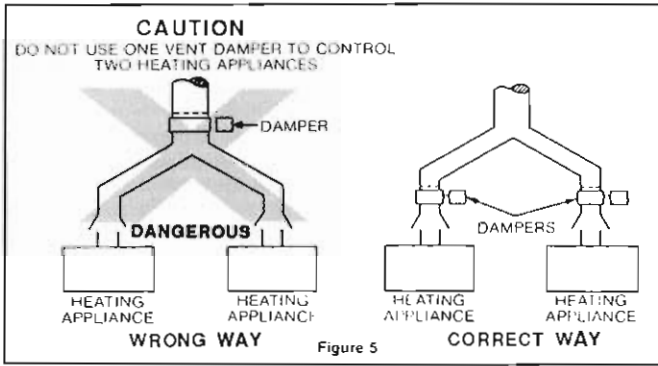

Figure 5

C. NOW, PROCEED AS FOLLOWS:

1. If Boiler is equipped with an Intermittent Ignition Pilot;
 - Remove the front cover of the boiler exposing the wiring compartment. With all electrical power to boiler off, locate "RECEPTACLE A" (see wiring diagram attached to boiler; a copy of this may also be found in this manual. To find the correct wiring diagram in this manual, match the number found in the lower right hand corner of the boiler wiring diagram with the identical number on one of the diagrams in this manual).
 - Cut the RED wire connected between numbers 3 and 4 of "RECEPTACLE A" (the only wire connected to this receptacle) and then disconnect "RECEPTACLE A" from "MALE PLUG". Remove "RECEPTACLE A" from job site and discard.
2. If boiler is equipped with a continuous (Standing) Pilot;
 - Remove front cover of the boiler exposing the wiring compartment. With electrical power to the boiler OFF, disconnect all 24 Volt control circuit wiring between high limit (pressure cut-out and low water cut-out if so equipped), thermostat, low limit controls and gas valves.
3. Separate the vent pipe directly on top of the draft hood or diverter and place damper in position as shown in Figures 1,2,4 and 5. The vent damper must be installed so that the damper position indicator is in a visible location after installation (see figure 4) for position indicator description. The arrow imprint on the open damper should point in direction of vent gas flow (towards chimney). Re-assemble the vent piping. Be sure the casting is well seated and fasten with 3 sheet metal screws. Screws should be no longer than 1/2 inch. See Figure 6.
4. Be sure that UNDERSIZED VENT PIPE DOES NOT BLOCK MOVEMENT OF DAMPER VANE (See Fig. 4)
5. All Slant/Fin "100" series and Galaxy HOT WATER boilers are equipped with INTERMITTENT PILOT Ignition Systems are factory wired. They require only the interchange of plugs and receptacles to make the final connection of the vent damper harness to the boiler controls. Those boilers equipped with CONTINUOUS (STANDING) PILOT Ignition Systems must be re-wired. Proceed as follows.

- a. Complete (1), (2) and (3) above and refer back to (1), or (2) whichever applies.
- b. Attach the flexible metallic conduit vent damper harness to the right hand side of the

jacket by passing the free end of the harness through the 7/8 dia. hole in the top of the jacket and using the BX connector at the free end of the metallic conduit fasten to jacket.

- c. (1) The vent damper carton contains another harness. The other is a 6 wire harness and has a male plug connected to one end of four of these wires. Use this 6 wire harness to re-wire ONLY those boilers equipped with a continuous (standing) pilot (see wiring diagram attached to boiler) and refer back to C.2.
 - (2) All Slant/Fin "100" series and Galaxy HOT WATER boilers equipped with INTERMITTENT PILOT IGNITION SYSTEMS are factory wired. They require only the interchange of plugs and receptacles to make the final connection of the vent damper harness to the boiler controls.
 - d. Connect "RECEPTACLE B" (free end of vent damper harness) into "MALE PLUG" (see correct wiring diagram for both continuous and intermittent pilots).
6. All Slant/Fin Corp. Galaxy STEAM, boilers equipped with INTERMITTENT PILOT Ignition Systems are factory wired except for the wires to the low water cut-off and pressure cut-off. Wire these controls with wire provided with boiler (see boiler wiring diagram on boiler). Then follow previous instructions shown in C. 5a,b,c and d.
 7. Restore electrical power and turn on gas supply.

D. AFTER INSTALLATION:

1. Operate system through two complete cycles to check for opening and closing in proper sequence, and proper burner operation. DAMPER MUST BE IN OPEN POSITION WHEN BOILER MAIN BURNERS ARE OPERATING.
 2. Perform installation checks as required by ANSI specification Z21.66.
 3. Replace the front cover of the boiler.
 4. Check the trouble-shooting section if problems arise with the installation.
- E. Thermostat Heat Anticipator Adjustment.

If the 24V room thermostat that controls this boiler has an adjustable heat anticipator and has previously been adjusted without a vent damper, add 0.1 to the heat anticipator setting when installing a SLANT/FIN model SP52 or SK19 Vent Damper. If room thermostat has not been adjusted, connect entire system to thermostat and run the system while measuring the current drawn through the thermostat wires. Set the heat anticipator at the value of current measured.

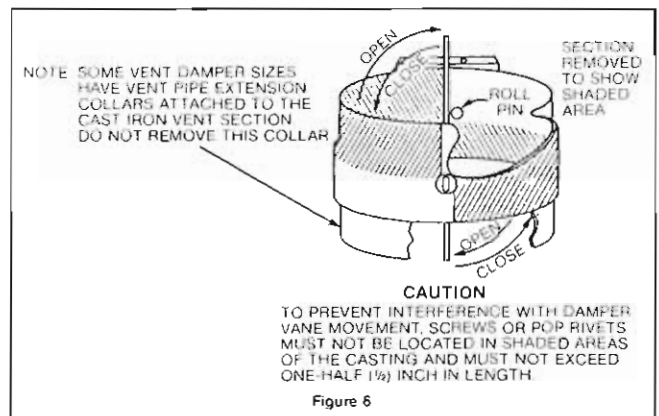

Figure 6

OPERATING INSTRUCTIONS, BASIC

Before firing boiler, make these checks:

1. Relief valve is installed. Valve opening is not closed or reduced in size.
2. Draft hood is installed and vented to chimney.
3. All wiring is completed, following applicable wiring diagrams.
4. If a vent damper is added, damper is in full open position. See instructions furnished with vent damper.
5. Using soap solution, check for gas leaks in all gas piping from meter to boiler pilot and manifold. Do not use open flame.

I. FILLING AND VENTING WATER SYSTEMS

- A. Fill the system with water. Vent or purge of air.
- B. Fire the boiler as soon as possible (see following warning and instructions) and bring water temperature to at least 180 degrees, while circulating water in the system.
- C. Vent air and add water as needed to achieve operating pressure on boiler gauge. Pressure must be between approximately 12 psi (cold water) and 25 psi (at water temperature setting of high limit control), for boilers equipped with 30 psi relief valves. Boilers rated for a higher pressure and equipped with a matching relief valve may operate at a higher pressure, but no higher than 5 psi below the relief valve opening pressure.
- D. Check for and repair any leaks before placing system in service.

II. CLEANING AND FILLING A NEW STEAM BOILER

Before using steam boiler:

- A. Check boiler to be certain it is ready for firing. **DO NOT FIRE** into an empty boiler.
- B. Be prepared to heat raw water to at least 180° F. as soon as it is introduced into the boiler. This procedure will remove dissolved, corrosive gases.
- C. Provide drain line, with valve, from boiler. Use a bottom tapping. Line and drain must be suitable for handling caustic solution.

III. CLEAN STEAM BOILER SYSTEM.

- A. Fill the boiler to water line indicated on the boiler.
- B. Follow start-up procedure for boiler and operate the boiler with steam in the entire system for 2 or 3 days to bring oil and dirt from the system to the boiler. While system is in operation, maintain the proper water level in the boiler by slowly adding water to the boiler.
- C. Shut down burner, cool down boiler and drain system.
- D. Procedure to dissolve oil and grease in boiler:
 1. Fill boiler to proper water line.
 2. Prepare a boil-out solution of *sodium hydroxide* (caustic soda) and *tri-sodium phosphate*.
NOTE: Use caution in handling chemicals. Caustic soda is harmful to skin, eyes and clothing.
(a) Proportions: 1 lb. of each chemical per 50 gallons of system water.
(b) Stir chemicals into water until dissolved and pour into the boiler through a top tapping. Replace plug.
 3. Start the burner; boil the water for at least 5 hours; shut off the burner.
- E. With CAUTION, drain the boiler solution to a safe location. **DO NOT LEAVE SOLUTION SITTING IN SYSTEM OVER 2 HOURS.**
- F. Wash the water side of the boiler thoroughly using a high pressure water stream. Fill and drain the boiler several times.

IV. TREATING WATER FOR CORROSION CONTROL

(This is not scale control).

- A. Prepare a solution of *sodium chromate*. Proportions: 1 lb. per 50 gallons of boiler water.
- B. Stir chemical in water until dissolved and pour into boiler through a top tapping. Replace plug.

V. FILLING AND VENTING THE STEAM BOILER.

- A. Refill the boiler to the indicated water line.
- B. Bring water to boiling temperature, promptly.
- C. The boiler is now ready to be put into service or on standby.

VI. INITIAL START

Safe lighting and other performance criteria were met when testing various gas manifold and control assemblies used on the Galaxy and 100 Series boilers under the ANSI Z21.13a 1983 Standard.

LIGHTING INSTRUCTIONS

Following the lighting instructions that apply to the particular ignition system equipped on this boiler. (Also, see figures on pages 2 & 3 for location of gas manifold, gas valve, and control assembly.)

1. **Constant Burning Pilot (24V or Millivolt).**
FOR BOILERS EQUIPPED WITH GAS VALVES V800, VS820, VR800, SX242NT and 36C03 (see figure 7).

FOR YOUR SAFETY READ BEFORE LIGHTING

WARNING: If you do not follow these instructions exactly, a fire or explosion may result causing property damage, personal injury or loss of life.

- A. This appliance has a pilot which must be lighted by hand. When lighting the pilot, follow these instructions exactly.
- B. **BEFORE LIGHTING** smell all around the appliance area for gas. Be sure to smell next to the floor because some gas is heavier than air and will settle on the floor.
WHAT TO DO IF YOU SMELL GAS
 - Do not try to light any appliance.
 - Do not touch any electric switch; do not use any phone in your building.
 - Immediately call your gas supplier from a neighbor's phone. Follow the gas supplier's instructions.
 - If you cannot reach your gas supplier, call the fire department.
- C. Use only your hand to push in or turn the gas control knob. Never use tools. If the knob will not push in or turn by hand, don't try to repair it, call a qualified service technician. Force or attempted repair may result in a fire or explosion.
- D. Do not use this appliance if any part has been under water. Immediately call a qualified service technician to inspect the appliance and to replace any part of the control system and any gas control which has been under water.

Lighting Instructions

1. **STOP!** Read the safety information above on this page.
2. Set the thermostat to lowest setting.
3. Turn off all electric power to the appliance.
4. Remove control access panel.
5. Push in gas control knob slightly and turn clockwise to "OFF".

Gas Control Knob Shown In "off" Position

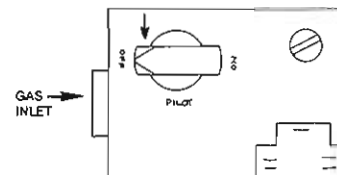

GAS VALVES V800, VS820 & SX242NT

Gas Control Knob Shown In "off" Position

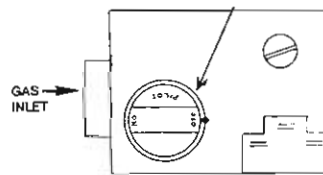

GAS VALVE VR800

Gas Control Knob Shown In "off" Position

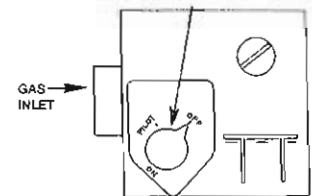

GAS VALVE 36C03

NOTE: Knob cannot be turned from "PILOT" to "OFF" unless knob is pushed in slightly. Do not force.

6. Wait five (5) minutes (longer for propane) to clear out any gas. If you then smell gas, STOP! Follow "B" in the safety information on previous page. If you don't smell gas, go to next step.
7. Remove the pilot access panel located below and behind the gas control unit.
8. Find pilot—follow metal tube from gas control. The pilot is between two burner tubes behind the pilot access panel. 
9. Turn knob on gas control counterclockwise to "PILOT".
10. Push in control knob all the way and hold in. Immediately light the pilot with a match. Continue to hold the control knob in for about one (1) minute after the pilot is lit. Release knob and it will pop back up. Pilot should remain lit. If it goes out, repeat steps 5 through 10.
 - If knob does not pop up when released, stop and immediately call your service technician or gas supplier.
 - If the pilot will not stay lit after several tries, turn the gas control knob to "OFF" and call your service technician or gas supplier.
11. Replace pilot access panel.
12. Turn gas control knob counterclockwise to "ON".
13. Replace control access panel.
14. Turn on all electric power to the appliance.
15. Set thermostat to desired settings.

To Turn Off Gas To Appliance

1. Set the thermostat to lowest setting.
2. Turn off all electric power to the appliance if service is to be performed.
3. Remove control access panel.
4. Push in gas control knob slightly and turn clockwise to "OFF". Do not force.
5. Replace control access panel.

2. Constant Burning Pilot (24V).

FOR BOILERS EQUIPPED WITH GAS VALVE VR820 (see figure 7).

FOR YOUR SAFETY READ BEFORE LIGHTING

WARNING: If you do not follow these instructions exactly, a fire or explosion may result causing property damage, personal injury or loss of life.

- A. This appliance has a pilot which must be lighted by hand. When lighting the pilot, follow these instructions exactly.
- B. BEFORE LIGHTING smell all around the appliance area for gas. Be sure to smell next to the floor because some gas is heavier than air and will settle on the floor. **WHAT TO DO IF YOU SMELL GAS**
 - Do not try to light any appliance.
 - Do not touch any electric switch; do not use any phone in your building.
 - Immediately call your gas supplier from a neighbor's phone. Follow the gas supplier's instructions.
 - If you cannot reach your gas supplier, call the fire department.
- C. Use only your hand to push in or turn the gas control knob. Never use tools. If the knob will not push in or turn by hand, don't try to repair it, call a qualified service technician. Force or attempted repair may result in a fire or explosion.
- D. Do not use this appliance if any part has been under water. Immediately call a qualified service technician to inspect the appliance and to replace any part of the control system and any gas control which has been under water.

Lighting Instructions

1. STOP! Read the safety information above on this page.
2. Set the thermostat to lowest setting.
3. Turn off all electric power to the appliance.
4. Remove control access panel.
5. Turn gas control knob clockwise to "OFF".

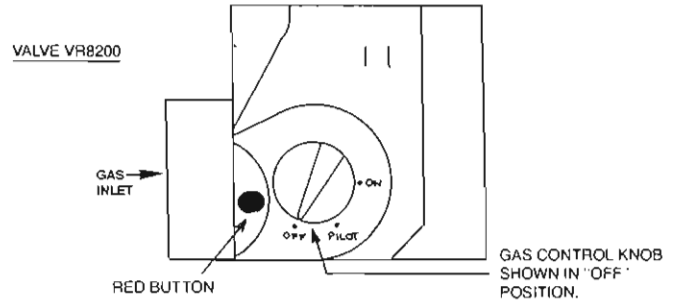

6. Wait five (5) minutes (longer for propane) to clear out any gas. If you then smell gas, STOP! Follow "B" in the safety information above on this page. If you don't smell gas, go to next step.
7. Remove the pilot access panel located below and behind the gas control unit.
8. Find pilot—follow metal tube from gas control. The pilot is between two burner tubes behind the pilot access panel. 
9. Turn knob on gas control counterclockwise to "PILOT".
10. Push in red button all the way and hold in. Immediately light the pilot with a match. Continue to hold the red button in for about one (1) minute after the pilot is lit. Release button and it will pop back up. Pilot should remain lit. If it goes out, repeat steps 5 through 10.
 - If knob does not pop up when released, stop and immediately call your service technician or gas supplier.
 - If the pilot will not stay lit after several tries, turn the gas control knob to "OFF" and call your service technician or gas supplier.
11. Replace pilot access panel.
12. Turn gas control knob counterclockwise to "ON".
13. Replace control access panel.
14. Turn on all electric power to the appliance.
15. Set thermostat to desired settings.

To Turn Off Gas To Appliance

1. Set the thermostat to lowest setting.
2. Turn off all electric power to the appliance if service is to be performed.
3. Remove control access panel.
4. Turn gas control knob clockwise to "OFF". Do not force.
5. Replace control access panel.

FIGURE 7

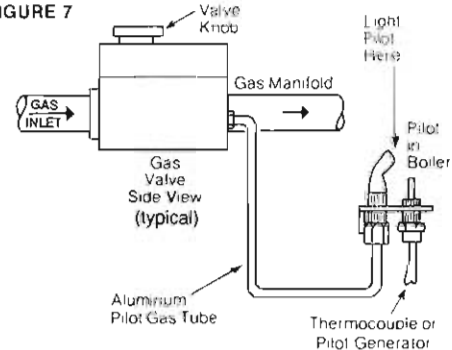

**3. WHITE RODGERS IID SYSTEM FOR NATURAL GAS ONLY.
FOR BOILERS EQUIPPED WITH GAS VALVE 36C84 (see figure 8).**

FOR YOUR SAFETY READ BEFORE OPERATING



WARNING: If you do not follow these instructions exactly, a fire or explosion may result causing property damage, personal injury or loss of life.

- This appliance is equipped with an ignition device which automatically lights the pilot. Do not try to light the pilot by hand.
- BEFORE OPERATING** smell all around the appliance area for gas. Be sure to smell next to the floor because some gas is heavier than air and will settle on the floor.
WHAT TO DO IF YOU SMELL GAS
 - Do not try to light any appliance.
 - Do not touch any electric switch; do not use any phone in your building.
 - Immediately call your gas supplier from a neighbor's phone. Follow the gas supplier's instructions.
 - If you cannot reach your gas supplier, call the fire department.
- Use only your hand to push in or turn the gas control knob. Never use tools. If the knob will not push in or turn by hand, don't try to repair it, call a qualified service technician. Force or attempted repair may result in a fire or explosion.
- Do not use this appliance if any part has been under water. Immediately call a qualified service technician to inspect the appliance and to replace any part of the control system and any gas control which has been under water.

Operating Instructions

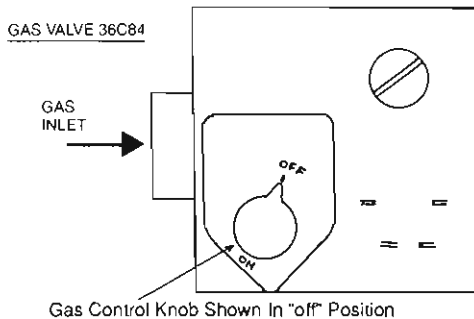
- STOP!** Read the safety information above on this page.
- Set the thermostat to lowest setting.
- Turn off all electric power to the appliance.
- This appliance is equipped with an ignition device which automatically lights the pilot. Do not try to light the pilot by hand.



- Remove control access panel.
- Turn gas control knob clockwise  till knob stops, push in knob slightly then continue to "OFF".
NOTE: Knob cannot be turned to "OFF" unless knob is pushed in slightly. Do not force.
- Wait five (5) minutes (longer for propane) to clear out any gas. If you then smell gas, STOP! Follow "B" in the safety information above on this page. If you don't smell gas, go to next step.
- Turn gas control knob counterclockwise  till knob stops, release, then continue to "ON".
- Replace control access panel.
- Turn on all electric power to the appliance.
- Set thermostat to desired setting.
- If the appliance will not operate, follow the instructions "To Turn Off Gas To Appliance" and call your service technician or gas supplier

To Turn Off Gas To Appliance

- Set the thermostat to lowest setting.
- Turn off all electric power to the appliance if service is to be performed.
- Remove control access panel.
- Turn gas control knob clockwise  till knob stops, push in knob slightly then continue to "OFF". Do not force.
- Replace control access panel.

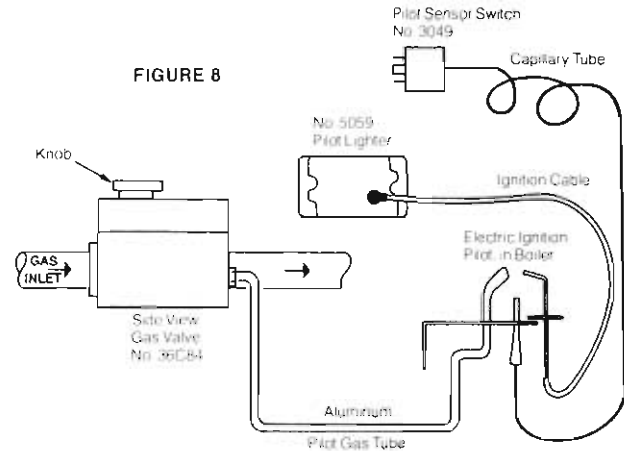

**4. HONEYWELL IID SYSTEM FOR NATURAL GAS ONLY.
FOR BOILERS EQUIPPED WITH GAS VALVE VR8440 (see figure 9).**

FOR YOUR SAFETY READ BEFORE OPERATING

WARNING: If you do not follow these instructions exactly, a fire or explosion may result causing property damage, personal injury or loss of life.

- This appliance is equipped with an ignition device which automatically lights the pilot. Do not try to light the pilot by hand.
- BEFORE OPERATING** smell all around the appliance area for gas. Be sure to smell next to the floor because some gas is heavier than air and will settle on the floor.
WHAT TO DO IF YOU SMELL GAS
 - Do not try to light any appliance.
 - Do not touch any electric switch; do not use any phone in your building.
 - Immediately call your gas supplier from a neighbor's phone. Follow the gas supplier's instructions.
 - If you cannot reach your gas supplier, call the fire department.
- Use only your hand to push in or turn the gas control knob. Never use tools. If the knob will not push in or turn by hand, don't try to repair it, call a qualified service technician. Force or attempted repair may result in a fire or explosion.
- Do not use this appliance if any part has been under water. Immediately call a qualified service technician to inspect the appliance and to replace any part of the control system and any gas control which has been under water.

Operating Instructions

- STOP!** Read the safety information above.
- Set the thermostat to lowest setting.
- Turn off all electric power to the appliance.
- This appliance is equipped with an ignition device which automatically lights the pilot. Do not try to light the pilot by hand.

GAS VALVE VR8440

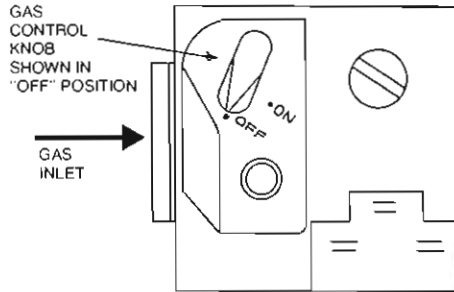

5. Remove control access panel.
6. Turn gas control knob clockwise till knob stops continue to "OFF". Do not force.
7. Wait five (5) minutes (longer for propane) to clear out any gas. If you then smell gas, STOP! Follow "B" in the safety information. If you don't smell gas, go to next step.
8. Turn gas control knob counterclockwise till knob stops, push in knob, then continue to "ON".
9. Replace control access panel.
10. Turn on all electric power to the appliance.
11. Set thermostat to desired setting.
12. If the appliance will not operate, follow the instructions "To Turn Off Gas To Appliance" and call your service technician or gas supplier.

To Turn Off Gas To Appliance

1. Set the thermostat to lowest setting.
2. Turn off all electric power to the appliance if service is to be performed.
3. Remove control access panel.
4. Turn gas control knob clockwise till knob stops, then continue to "OFF". Do not force.
5. Replace control access panel.

5. HONEYWELL IID SYSTEM FOR NATURAL GAS ONLY. FOR BOILERS EQUIPPED WITH GAS VALVE VR8204 (see figure 9).

FOR YOUR SAFETY READ BEFORE OPERATING

WARNING: If you do not follow these instructions exactly, a fire or explosion may result causing property damage, personal injury or loss of life.

- A. This appliance is equipped with an ignition device which automatically lights the pilot. Do not try to light the pilot by hand.
- B. BEFORE OPERATING smell all around the appliance area for gas. Be sure to smell next to the floor because some gas is heavier than air and will settle on the floor.

WHAT TO DO IF YOU SMELL GAS

 - Do not try to light any appliance.
 - Do not touch any electric switch; do not use any phone in your building.
 - Immediately call your gas supplier from a neighbor's phone. Follow the gas supplier's instructions.
 - If you cannot reach your gas supplier, call the fire department.
- C. Use only your hand to push in or turn the gas control knob. Never use tools. If the knob will not push in or turn by hand, don't try to repair it, call a qualified service technician.

Force or attempted repair may result in a fire or explosion.

- D. Do not use this appliance if any part has been under water. Immediately call a qualified service technician to inspect the appliance and to replace any part of the control system and any gas control which has been under water.

Operating Instructions

1. STOP! Read the safety information above on this page.
2. Set the thermostat to lowest setting.
3. Turn off all electric power to the appliance.
4. This appliance is equipped with an ignition device which automatically lights the pilot. Do not try to light the pilot by hand.

GAS VALVE VR8204

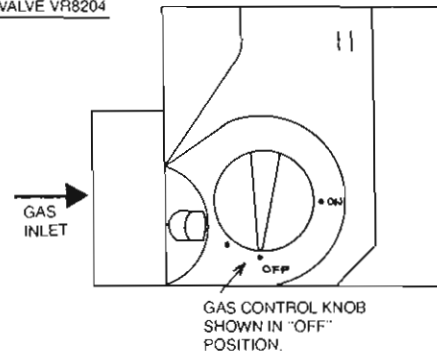

5. Remove control access panel.
6. Turn gas control knob clockwise to "OFF". Do not force.
7. Wait five (5) minutes (longer for propane) to clear out any gas. If you then smell gas, STOP! Follow "B" in the safety information above on this page. If you don't smell gas, go to next step.
8. Turn gas control knob counterclockwise to "ON".
9. Replace control access panel.
10. Turn on all electric power to the appliance.
11. Set thermostat to desired setting.
12. If the appliance will not operate, follow the instructions "To Turn Off Gas To Appliance" and call your service technician or gas supplier

To Turn Off Gas To Appliance

1. Set the thermostat to lowest setting.
2. Turn off all electric power to the appliance if service is to be performed.
3. Remove control access panel.
4. Turn gas control knob clockwise to "OFF". Do not force.
5. Replace control access panel.

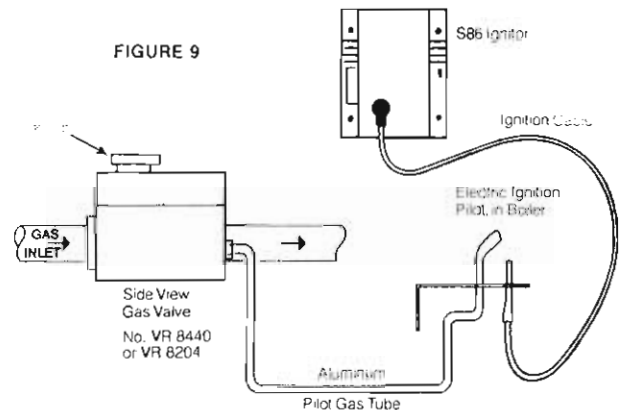

VII. BURNER ADJUSTMENT

A. Adjust gas input rate:

1. Consult gas supplier for heating value of gas (Btu/cu. ft.).
2. Set thermostat high enough so that boiler will remain on while checking rate.
3. Measure manifold pressure at 1/8" tapping. Correct manifold pressure for gas used is printed on boiler rating plate. NOTE: Gas pressure may be adjusted by turning pressure regulator screw on combination gas valve (Turn clockwise to increase pressure, counter clockwise to decrease pressure).

a. Input for PROPANE is approximately at rating shown on rating plate when manifold pressure is 9-1/2" water column.

b. Input for NATURAL GAS is approximately at rating when manifold pressure is 3-1/2" water column, but should be checked on the gas meter:

$$\text{Btuh Input} = \text{Btuh/cu. ft.} \times \text{cu. ft. metered in 3 minutes} \times 20$$

For 1000 Btu/cu. ft. gas, this becomes:

$$\text{Btuh Input} = \text{cu. ft. metered in 3 minutes} \times 20,000$$

The gas metered in 3 minutes to obtain rated input for each boiler model, using 1000 Btu/cu. ft. gas, is tabulated in gas rate table.

GAS RATE TABLE

Boiler rated input in cu. ft./hr. of 1000 Btu/cu. ft. Natural Gas*	Cubic Feet Gas Consumption 1000 Btu/cu. ft. gas, in 3 minutes, at rated input
75	3.75
100	5
125	6.25
150	7.5
175	8.75
200	10
225	11.25
250	12.5
275	13.75
300	15
325	16.25
350	17.5
375	18.75

*GG/GX model number is rated input in thousands of Btuh, or cu. ft. per hour of 1000 Btu/cu. ft. gas.

B. Main Burner

1. Fire the boiler continuously for at least 15 minutes, to reach burner operating temperature.
2. Observe the flames, all burners. The base of all flame jets should be blue. The tips should be blue shading to orange. NOTE: Dust, disturbed by any movement, will cause bright orange flames. Wait for dust settle.
3. For one burner, close the air shutter until some of its flame jet tips turn yellow-white, indicating insufficient primary air. Then open shutter until whitish tips disappear completely. Set all burner shutters to the same opening. Observe to make sure that no yellow-white tips appear over any portion of the flame. Small yellow tips at the pilot location are permitted.

NOTE: This adjustment method gives MINIMUM primary air setting for safe combustion. Do not attempt to make this adjustment unless burners are at operating temperature. Adjustment should be made with doors in final operating position. Use of mirror may be helpful to observe flames. Note that burner ports are on top of main burner tube.

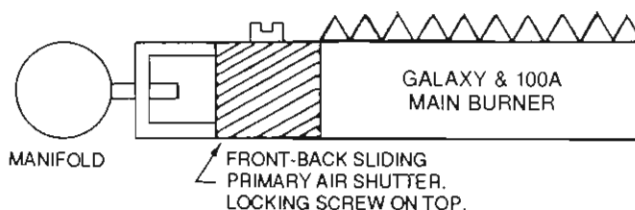

C. Main Burner Ignition Checkout and Pilot Adjustment

1. The pilot flame must not smother or snuff out when tested as follows:

- a. Main burner ignition from cold start-repeat.
- b. Continued operation of main burner.
- c. Main burner ignition with appliance at maximum operating temperature after prolonged operation.

NOTE: Observe operation of the pilot burner with appliance doors in the final operating position. Use of a mirror may be helpful.

2. Safety Shutdown Checkout

a. Make certain the pilot burner holds in, and the power-pile valve (if used) opens properly, when the pilot is burning normally; and that safety shutdown occurs within 2-1/2 minutes after the pilot flame is extinguished. Observe operation for at least one cycle under automatic control to be sure the system is functioning normally.

b. For proper operation the pilot should engulf the thermocouple, powerpile generator of flame sensor as shown below.

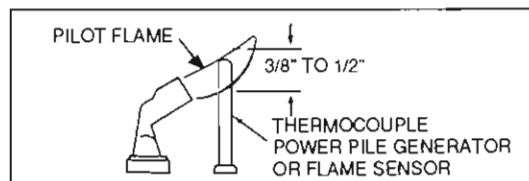

- c. To adjust pilot, turn pilot flow adjustment screw on valve clockwise or counter clockwise to give a steady flame enveloping 3/8" to 1/2" of the tip of the thermocouple, generator of flame sensor. Note that turning the pilot adjust screw clockwise will decrease the pilot flame.
- d. Check safety shutdown of gas valve by following procedure outlined "CARE" and "MAINTENANCE" section.

VIII. CONTROLS, SAFETY CHECK

Check all safety controls not previously mentioned. Also, follow directions in "CARE AND MAINTENANCE" section, paragraphs IV through VII.

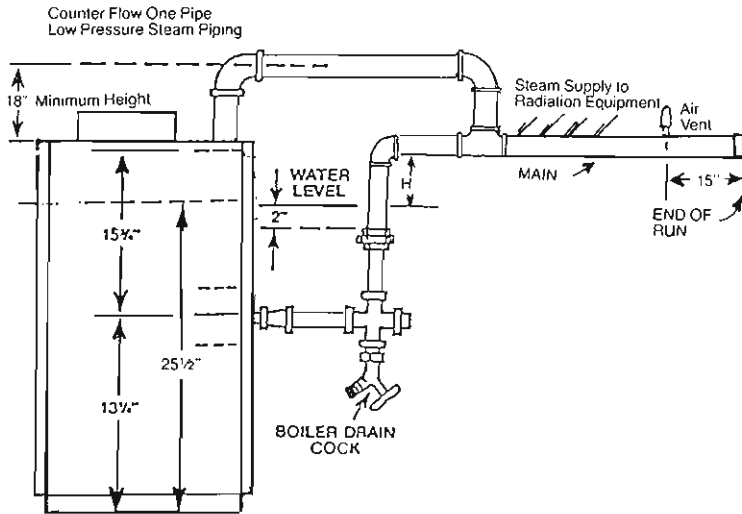

Figure 3

Counter flow piping is sized one pipe size larger than a parallel flow piping. This allows steam to travel in one direction while the condensate travels in the other direction. This along with a steeper pitch is a must for safe, efficient operation.

LOW WATER CUT-OFF CHECK-OUT

- A. Electronic Probe Type Low Water Cut-off. If this boiler is factory equipped with an electronic probe type low water cut-off, operation of cut-off should be checked at least twice a year as follows.
 1. While boiler is running, drain down boiler water slowly through Boiler Drain Cock shown on page 7 or 8, just until light goes on. Boiler should shut down 90 seconds after light goes on.
 2. Be sure that it is the low water cut-off and not the room thermostat, pressure cut-out, energy cut-off or other control that has shut-off the burner.
 3. Refill the boiler and repeat test.
 4. Refill the boiler and reset controls for normal operation.
- B. Float type low water cut-off
 If this boiler is factory equipped with a McDonnell & Miller float type low water cut-off, the low water cut-off must be blown down (flushed), at least once a week.
CAUTION: When flushing float type low water cut-off control, hot water and steam will flow out the blow down valve. Blow down valve is illustrated on page 6
 Steam controls assembly.

1. **SPECIAL FLUSHING INSTRUCTIONS**
 Installation of new boiler may break loose a heavy accumulation of sediment and scale from old piping and radiators. It is extremely important to blow down your McDonnell Cut-off more frequently the first week.
 First week — 3 times
 Thereafter — at least once a week

2. As boiler water circulates through the float chamber, dirt or other sediment may be deposited. This chamber is extra deep. But the only sure way to keep any accumulation from interfering with float action is to "blow down," or flush out, the control once a week.
 Do it while boiler is in operation. First note water level in gauge glass. Open blow-off valve at bottom of control; water will pour out, flushing away sediment. Drain until water is clear—about a pail—then close valve. If level in gauge glass has dropped, add water to boiler to restore level.
3. NOTE: Opening blow-off valve checks cut-off operation too. As float drops with falling water level, burner will stop. After valve is closed and normal operating conditions restored, burner will resume firing.
4. Be sure that it is the low water cut-off and not the room thermostat, pressure cut-out, energy cut-off or other control that has shut off the burner.

PRESSURE CONTROL CHECK-OUT

- A. Check burner to be certain it is ready for firing. **DO NOT FIRE** into an empty boiler.
- B. Set thermostat high enough for boiler to make steam. Set the pressure control down to its lowest setting. As the boiler starts to produce steam, the steam pressure will start to build. The burner will shut-off when the steam pressure exceeds the pressure setting (plus differential if the control has this feature).
- C. Adjust the pressure control to a higher setting. The higher setting should be above the steam pressure in the boiler. This should turn the burner back on.
- D. Reset the pressure control as needed for the system. The pressure control should be checked out at least twice a year.

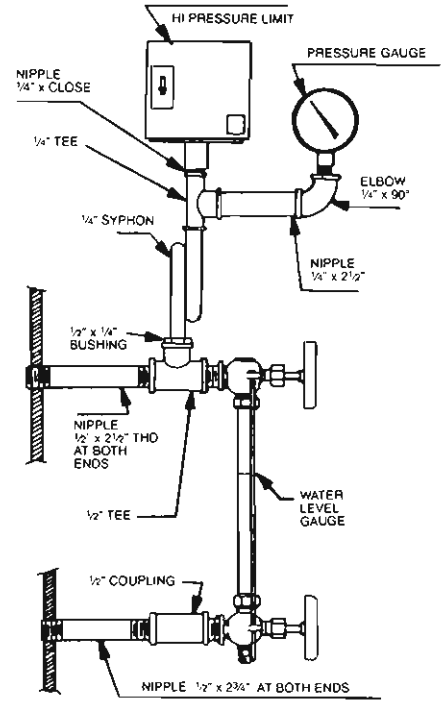

Steam Controls Installation Instructions

Steam kit components for Galaxy packaged models are packed as follows:

1. Low water cut-off control, electric, installed.
2. Pressure gauge.
3. High pressure limit control.
4. Water level gauge.
5. Fittings
6. Instruction sheet and assembly drawing.
7. Steam safety valve and 3/4" street coupling.
8. Drain cock.

Assembly above components exactly as shown. Two 1/2" tappings are on right side of boiler for this assembly. Two holes are pre-punched in jackets.

Replacement of Steam Boilers

Anytime an older steam boiler is removed from the heating system and replaced with a new boiler, there are certain conditions that have to be examined on the heating system.

1. Steam systems have a tendency to develop scale inside the wet return lines and the boiler. The older the system the greater the accumulation of scale that can exist inside the piping. Therefore, it is necessary when replacing a steam boiler to check the piping for blockage or restrictions. Clean or replace the piping as required. (See special flushing instructions page 16.)
2. Replace all buried wet return lines.
3. All equipment (air vents, radiation equipment, etc.) in the steam heating system should be checked for proper operation. All piping should be checked for proper pitch.
4. It is good engineering practice to repack or tighten the packing nuts on all valves in the heating system.

BLOWING OFF A LOW PRESSURE STEAM BOILER

1. MODELS THAT HAVE NO TANKLESS HEATER OR NO PROVISION FOR HEATER

- Those models without tankless heaters or provision for tankless heaters have a skimmer giving the advantages of a surface blow pipe, that has been built into the casting to insure rapid skimming of oil and grease through a 3/4 N.P.T. tapping located on the right hand jacket side panel, 8-3/8" from the top and 13-1/4" from the front of the boiler (See Fig. A).
- Turn off electrical power supply to boiler. Allow boiler to cool down and steam pressure to reduce to zero before removing skimmer tapping plug. Check for steam pressure by testing the pop safety valve. Keep your hands and all parts of your body away from the discharge end of the safety valve. Drain boiler down one to two inches below skimmer tapping. There will be water in the skimmer trough. The water might be hot. Remove skimmer plug slowly and carefully. Install 3/4" skimmer valve, elbow and length of pipe and place a bucket underneath the open end of the pipe. Cover bucket with a piece of cloth.
- Fill boiler slowly until water level is two inches from top of gauge glass. (This is the starting water level for skimming only.) Fire boiler to produce steam. If the system is heavily laden with oil, it may be difficult to obtain much more than a pound or so of pressure. Set the pressure control at about 7 psi. The higher the steam pressure you can use, the better and faster the cleaning.
- As steam develops, open the SKIMMER drain valve with caution to skim the oil and film from the top of the water. DO NOT open the boiler drain valve. Close the skimmer drain valve when the water level drops to about 5" from the top of the gauge glass. The water may stop before the level drops to 5" below the top of the glass. Refill boiler until water level is again two inches from the top of the gauge glass.
- Repeat (D) above until all film is skimmed off and the water settles to a desired normal movement. Add make up fresh water to the boiler as described in (D) above during the blow-off operation to maintain the proper skimming water level in the vessel. Empty bucket frequently in order to see the difference in water cleanliness.
- When surging has stopped and water is clean, and no film can be seen floating in the bucket, shut off boiler, drain down to level of skimmer tapping, remove valve, plug skimmer tapping and refill the

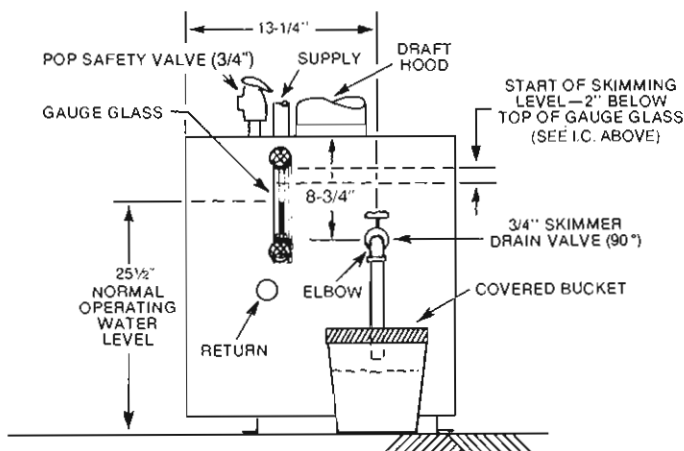

FIGURE A
Right side view of Galaxy models that are NOT equipped with or DO NOT have provisions for tankless heaters.

boiler to the normal operating water level (25-1/2" from the bottom of the boiler—see figure A below). Check the pop safety valve for proper operation.

- The entire process may have to be repeated over a period of a few days on extremely fouled systems.
- ### 2. MODELS WITH TANKLESS HEATER OR WITH TANKLESS HEATER PLATES ONLY.
- Turn off electrical power supply to boiler. Allow boiler to cool down and allow pressure to reduce to zero before attempting removal of components. Check for steam pressure by testing safety valve. Keep your hands and body away from the discharge end of the valve. Remove pop safety valve and re-pipe boiler as shown in Figure (B) below, making sure to reinstall pop safety valve on tee to complete the blow off connection.
 - Connect a length of pipe to the elbow and place a bucket underneath the open end of the pipe, cover bucket with a piece of cloth.
 - Open the SKIMMER drain valve with caution. DO NOT open the boiler drain valve. Fill the boiler slowly until water begins to seep into the bucket from the skimmer drain blow off connection. Fire the boiler. Allow water to heat up while water seeps into the bucket. Maintain that water level necessary just to be able to continue skimming. Continue until water is clean and no oil can be seen floating in the bucket. Empty bucket frequently in order to see if the water is clean.
 - Repeat this process until all film is skimmed off, lower the water level to 25-1/2 inches from the bottom of the boiler (see Figure (B) below). When all surging has stopped, turn off the boiler, remove skimmer valve and plug the tee. Check the pop safety valve for proper operation.
 - The entire process may have to be repeated over a period of a few days on extremely fouled systems.

3. CLEANING PIPING SYSTEM

- To clean piping system, open all valves at the heating elements, after getting up a good head of steam, shut the boiler down and allow the condensate to return to the boiler. The condensate will carry the oil film with it. Again blow-off the boiler. On extremely fouled systems, it may require several visits over a period of a few days to clean the system.
- When steam only (no water) is released through the hand valve, the boiler will not surge or flood.

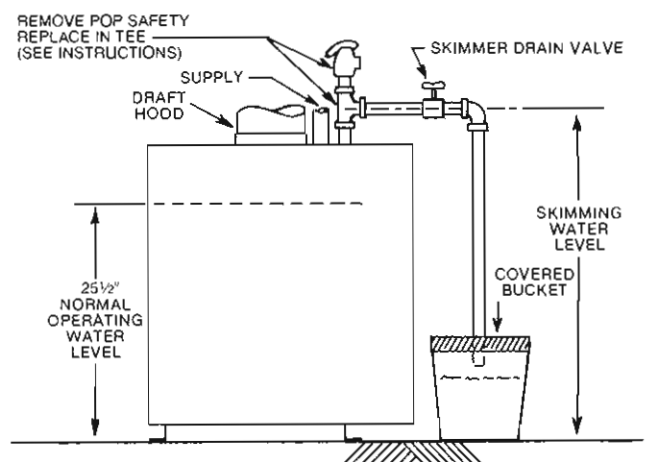

FIGURE B
Left side view of Galaxy models that are equipped with or have provisions for tankless heaters.

CARE AND MAINTENANCE

WARNING: THE FLOW OF COMBUSTION AND VENTILATING AIR TO THE BOILER SHOULD NOT BE OBSTRUCTED.

This section must be brought to the attention of the owner by the installer so that the owner can make the necessary arrangements with a qualified service agency for the periodic care and maintenance of this boiler. The installer must inform the owner that the gas supplier can recommend a number of qualified service agencies. The installer must also inform the owner that the lack of proper care and maintenance of this boiler and any fuel burning equipment may result in a hazardous condition.

I. GENERAL MAINTENANCE (Refer also to User's Information Manual)

These operations are recommended to be performed at regular intervals:

- A. **BOILER HEATING SURFACES:** clean off all coatings found.
- B. **BOILER CONTROLS:** check contacts, settings, correct functioning.
- C. **PIPING:** check piping and accessories for leaks.
- D. **CHIMNEY and BREECHING:** check for obstructions and leaks.
- E. **BOILER ROOM AIR SUPPLY:** check air vents for continued POSITIVE supply of air as required. Air needs are greatest in cold weather. Air vents must be open and free of obstruction.
- F. **WATER SYSTEM:** check
 1. System to be full of water, and pressure to remain stable at correct setting on gauge.
 2. Air-control system: noise and air binding in radiation should not occur.
 3. Water lines: slightest leaks should be corrected.
 4. Low water cutoff, for operation (see instructions furnished with unit.)

II. WATER LEVEL CHECK DURING HEATING SEASON:

- A. Check water level regularly and add water slowly to system when needed. If much water is added, venting may be necessary.
- B. Regular loss of water from water boiler system may indicate either a system leak, or a faulty air control system, or a faulty automatic fill valve.

III. ANNUAL INSPECTION AND CLEANING:

- A. It is important that this boiler be inspected by a competent serviceman to help insure safe and reliable operation.
- B. Check for gas leaks from valve and gas piping to burners and pilot. If leaks are found, repair or replace as required.
- C. This inspection should include:
 1. Controls check. See SAFETY CHECK, IV.
 2. Recheck of input gas rate to burners. See "Initial Start" paragraph in "Operating Instructions" section.
 3. Re-adjusting for best flame characteristics of main flame and pilot(s). See "Initial Start" paragraph in "Operating Instructions" section and see "Burner Adjustment" section.
 4. Burner and boiler flue passage cleanliness: **BURNER AND FLUE CLEANING** (see sketch). It is suggested that paper be placed on burners to collect any foreign material in cleaning flues.
 5. Remove draft hood, jacket top and flue cover.
 6. Use wire brush to clean flueways.
 7. Replace flue cover and re-seal with furnace cement. Replace jacket top and draft hood and reconnect to smoke pipe, using screws. Remove and dispose of paper and accumulated material.
 8. If burner surfaces are not clean, or if uneven flame indicates plugged burner ports, remove and clean burners.

NOTE—TO REMOVE GALAXY & 100A BURNERS:

- a. Remove holding wire clip at orifice.
- b. Disconnect pilot at pilot mount, or disconnect thermocouple and pilot gas line at gas valve, before removing burners next to pilot.
- c. Lift rear of burner and remove burner from orifice.

- d. Clean and replace burners* and pilot. Adjust burners as described on page 14.

* To clean burners run a clean flue brush up the tube until all foreign matter is removed.

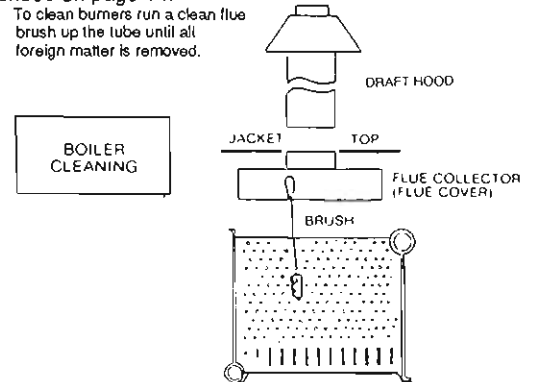

IV. SAFETY CHECK FOR CONTROL SYSTEM

- A. **High limit control test:** Set thermostat high enough for boiler water temperature to reach high limit control setting. When this temperature is reached, the high limit switch should open, and the main gas valve should close automatically. If the high limit does not operate to close the main gas valve, the valve, the high limit or the wiring is faulty. Repair or replace immediately.
- B. **Gas valve safety shutdown test:**
 1. For boiler equipped with constant burning pilot, with main burners firing, disconnect the thermocouple or thermopile generator from the gas valve. The gas valve should immediately shut off the main burners and the pilot.
 2. For boilers equipped with Honeywell S86 intermittent pilot system, with main burners firing, disconnect the ignition cable from the S86 IGNITOR BOX. The gas valve should shut off the main burners.
 3. For boilers equipped with White Rodgers intermittent pilot system, with main burners firing, disconnect the lead from No. 2 terminal on the No. 3049 pilot sensor switch. The gas valve should shut off the main burners. If the gas valve fails to shut down main burners when the test in 1, 2 or 3 is performed, replace the gas valve.
- C. Check for gas leaks from valve and gas piping to burners and pilot. If leaks are found, repair or replace as required.
- V. A. **Providing Protection from Freezing.**

Anti-freeze is sometimes used in hydronic heating systems to protect against freeze-up in the event of power failure or control shutdown when the building is unoccupied. It should be recognized that unless the building is kept above freezing temperature by some means, the plumbing system is not protected.

Two types of anti-freeze may be used: ETHYLENE GLYCOL, used in automobiles, has desirable properties, but is toxic. Its use may be prohibited when system water/glycol solution is in contact with a potable water vessel (as with a tankless heater). PROPYLENE GLYCOL is used in the quick-freeze food industry; it is practically non-toxic. Its use may be permitted when tankless heaters are used. When anti-freeze must be used, inhibited propylene glycol is recommended. Useful information on the characteristics, mixing proportions, etc. of glycol in heating systems is given in Technical Topics No. 2A, available from the Hydronics Institute 34 Russo Place, Berkeley Heights, NJ 07922. Consult glycol manufacturers for sources of propylene glycol.

B. Water Treatment:

A good water treatment program will not only extend the useful life of this boiler but it will also save much of the time and expense of repairs made necessary by preventable occurrences.

A reputable water treatment company should be consulted to evaluate and determine the best overall treatment program for your boiler equipment.

VI. KEEP THE BOILER AREA CLEAR AND FREE FROM COMBUSTIBLE MATERIALS, GASOLINE, AND OTHER FLAMMABLE VAPORS AND LIQUIDS.

BASIC WIRING DIAGRAMS — CONSTANT PILOT WITH ENERGY CUTOFF

All models with constant pilot and input of 300,000 Bth/Hr or greater and all millivolt ignition systems are equipped with an energy cutoff. DO NOT USE WITH VENT DAMPER.

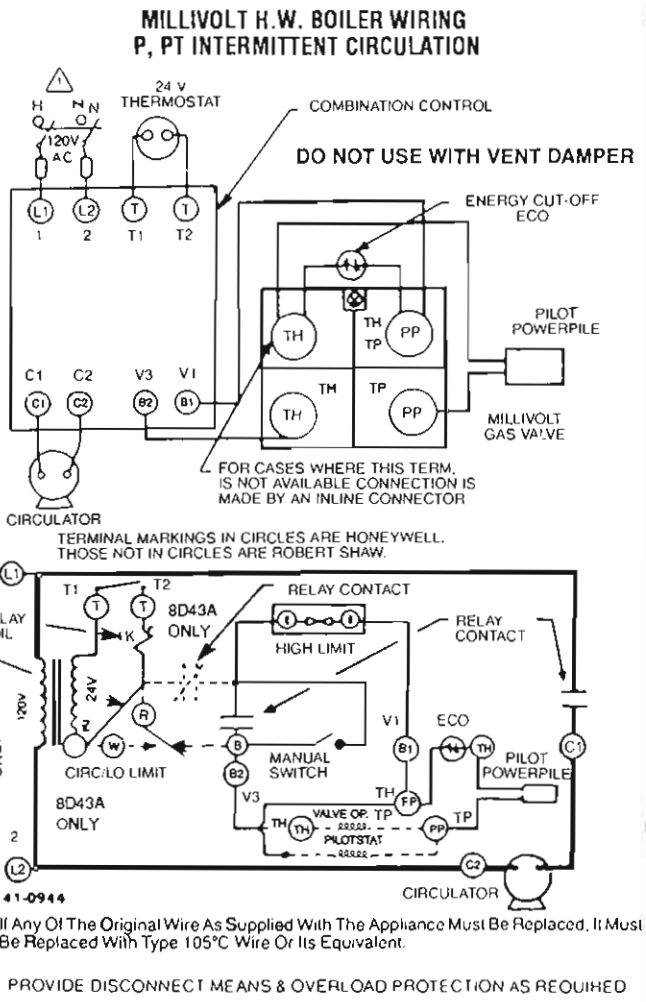
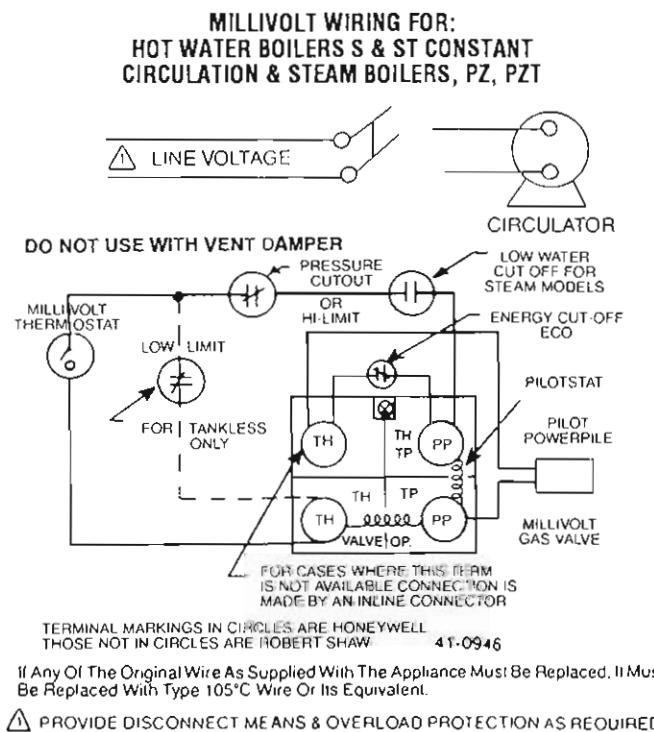
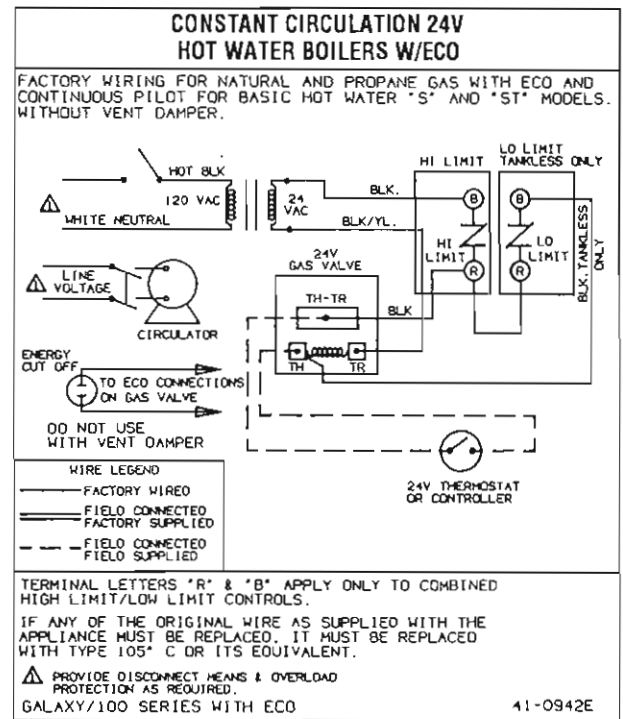
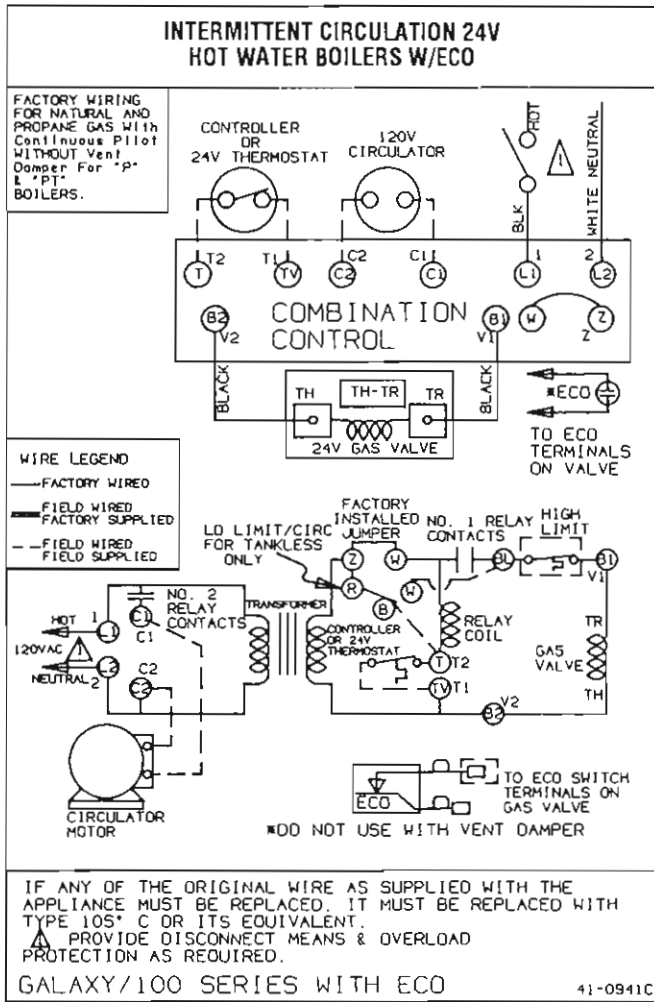

BASIC WIRING DIAGRAMS — CONSTANT PILOT WITH ENERGY CUTOFF

All models with constant pilot and input of 300,000 Bth/Hr or greater and all millivolt ignition systems are equipped with an energy cutoff. DO NOT USE WITH VENT DAMPER.

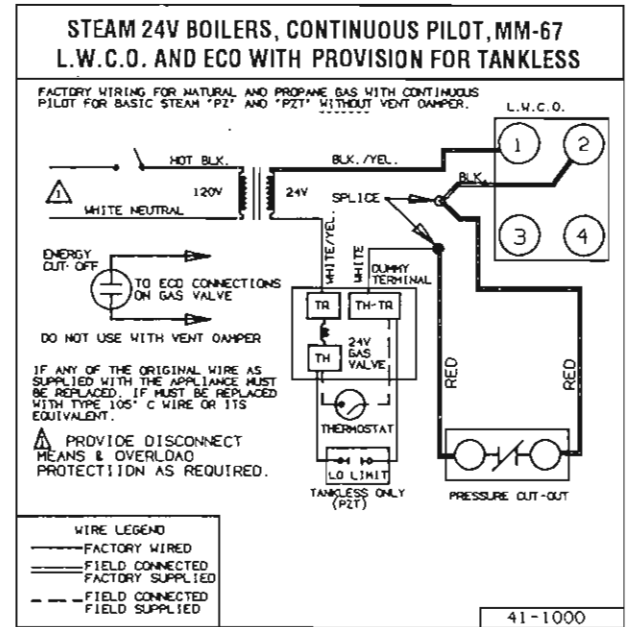
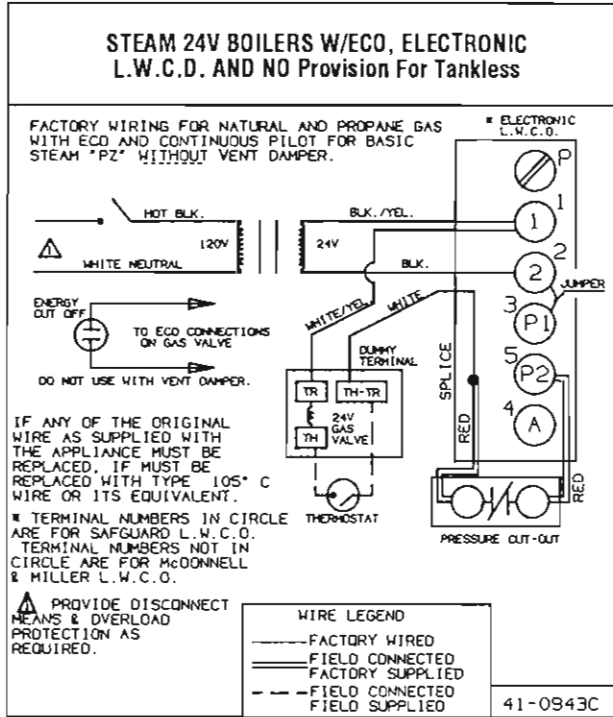

SEQUENCE OF OPERATION OF SLANT/FIN BOILERS EQUIPPED WITH CONSTANT BURNING PILOTS FOR DIAGRAMS SHOWN ON PAGE 18, 19, 21 & 22.

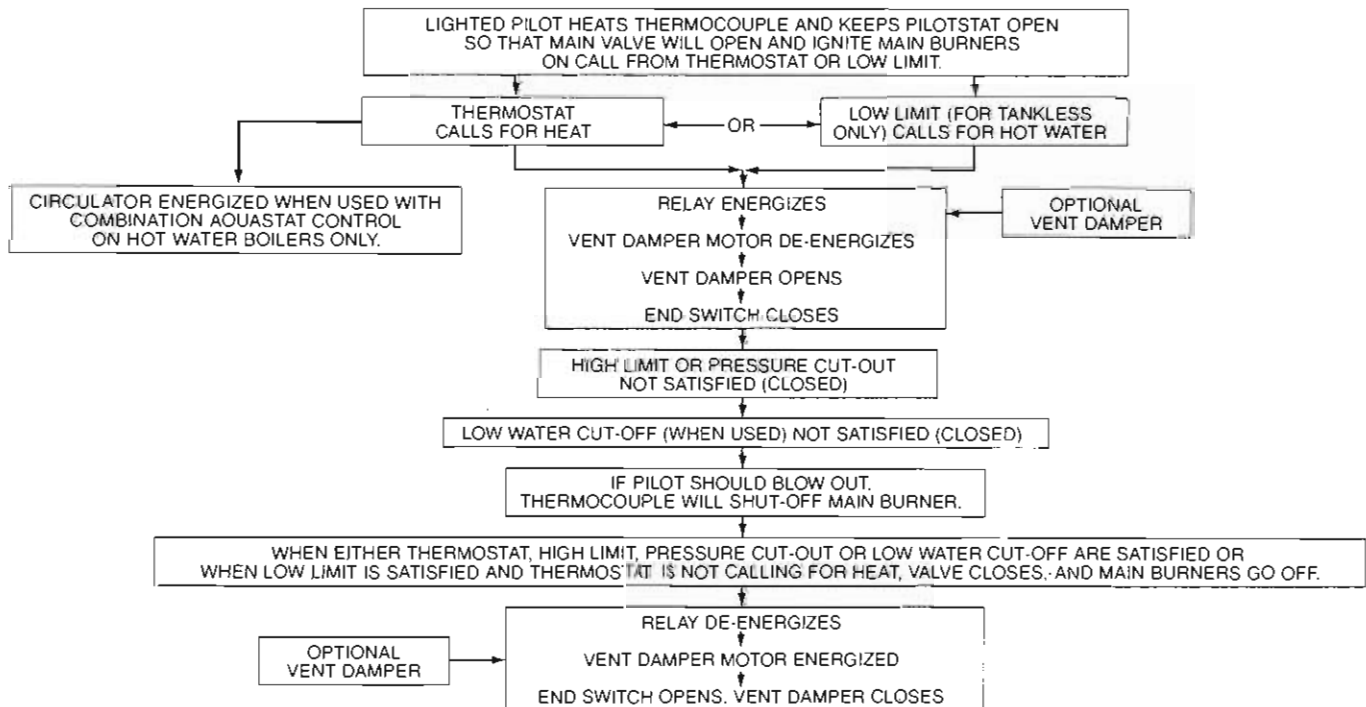

**SEQUENCE OF OPERATION OF SLANT/FIN BOILERS EQUIPPED WITH WHITE RODGERS
INTERMITTENT IGNITION SYSTEM FOR DIAGRAMS SHOWN ON PAGES 23-25.**

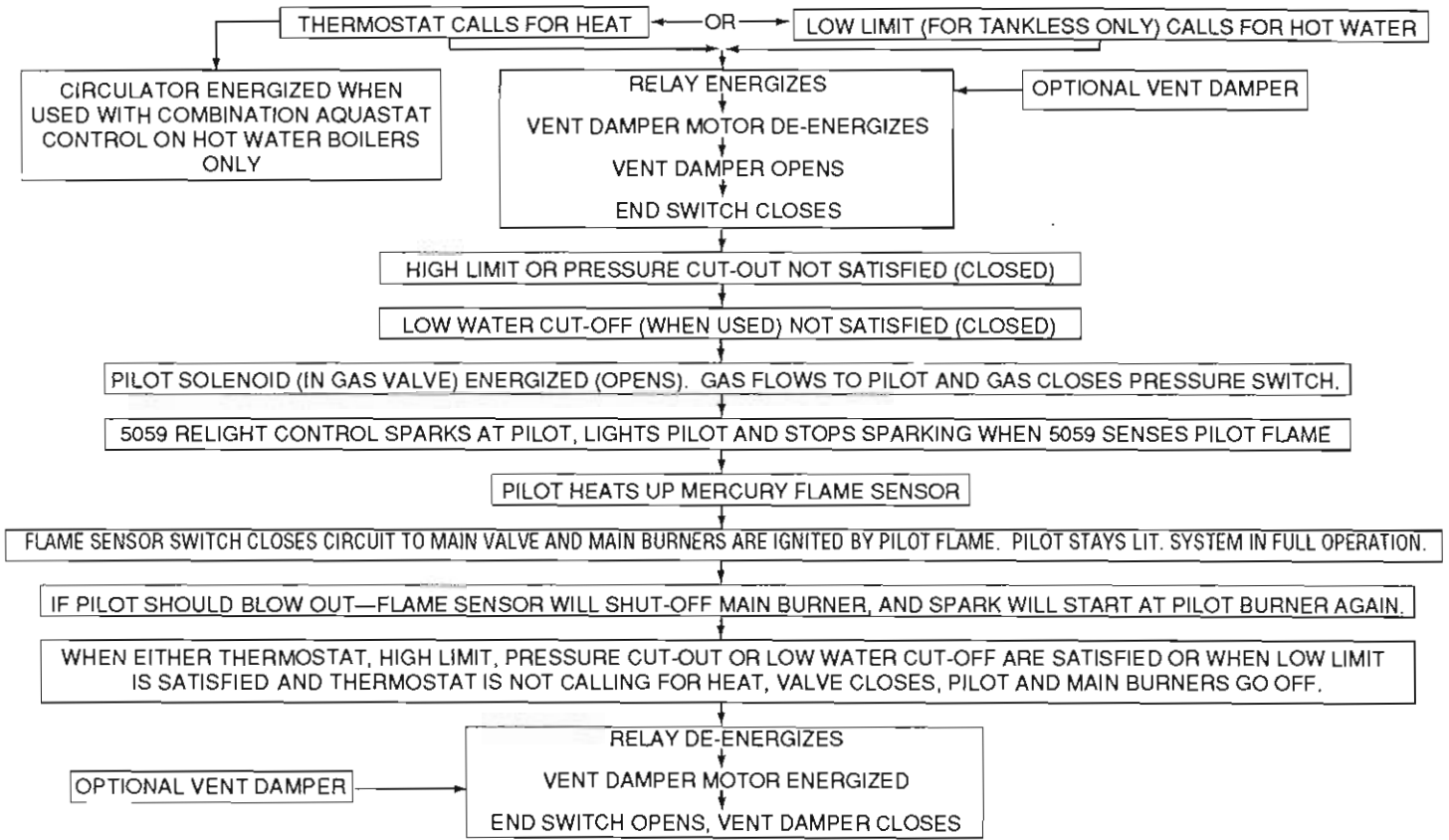

**SEQUENCE OF OPERATION OF SLANT/FIN BOILERS EQUIPPED WITH HONEYWELL
INTERMITTENT IGNITION SYSTEM FOR DIAGRAMS SHOWN ON PAGES 23-25.**

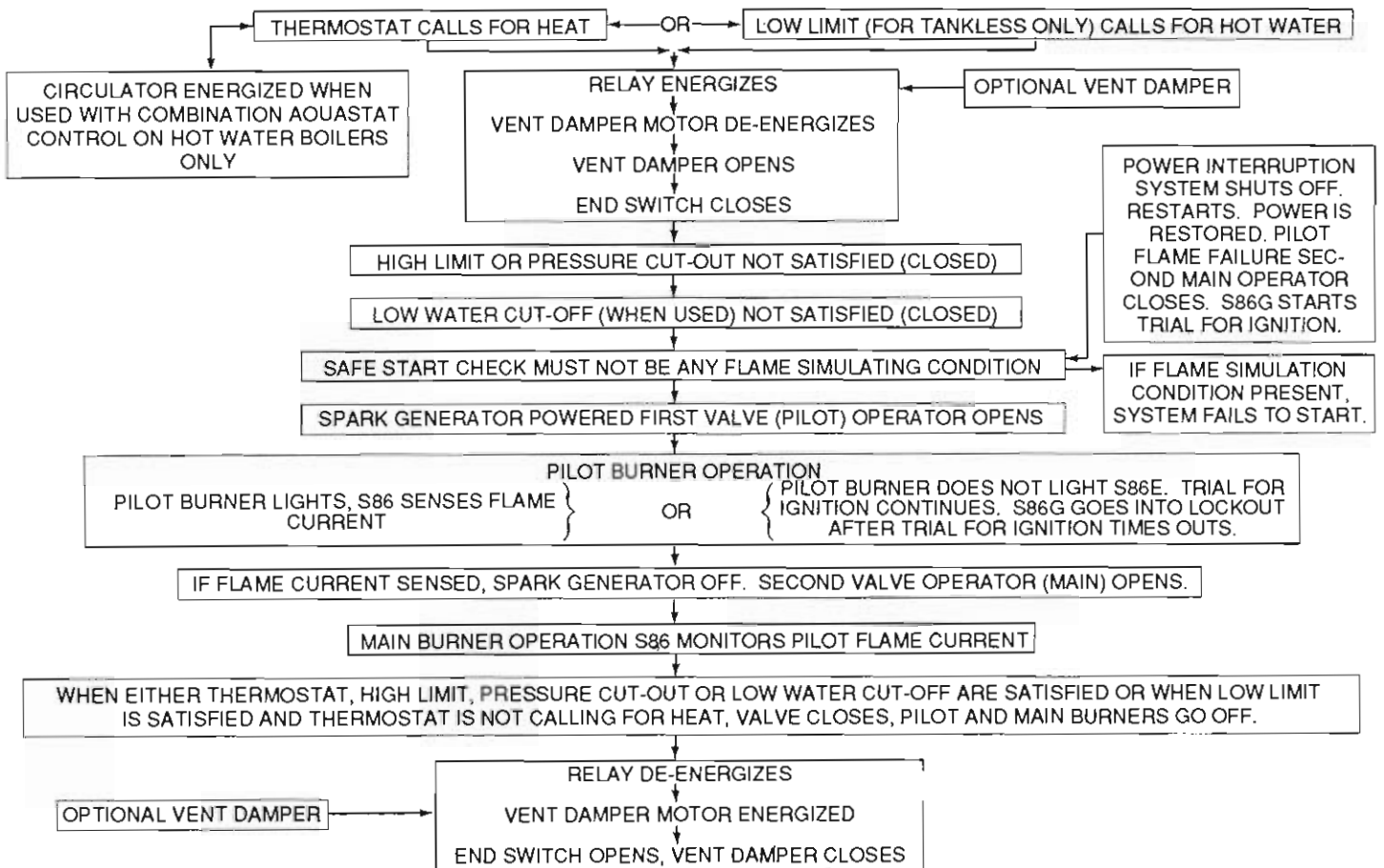

BASIC WIRING DIAGRAMS — CONSTANT PILOT

STEAM 24V CONTINUOUS PILOT, ELECTRONIC L.W.C.O. BOILERS And NO Provision For Tankless

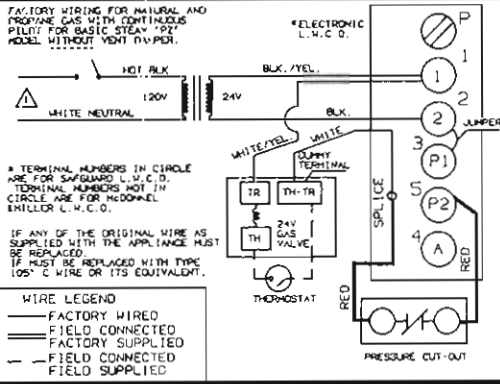

BELOW:
Field Wiring ONLY WITH SLANT/FIN Vent Damper And Continuous Pilot For Basic Steam 'P2' Model

WARNING
BEFORE INSTALLING OPTIONAL VENT DAMPER READ WARNING LABEL ON THIS BOILER AND VENT DAMPER. READ SLANT/FIN VENT DAMPER INSTALLATION INSTRUCTIONS AND REMOVE ALL EXISTING WIRING FROM BOILER EXCEPT WIRING FROM L.W.C.O. TO TRANSFORMER BEFORE REWIRING FOR VENT DAMPER.

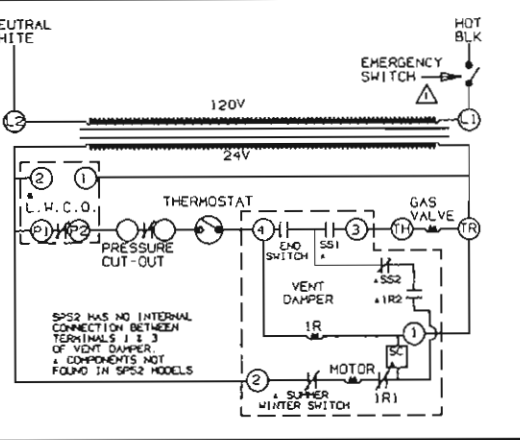
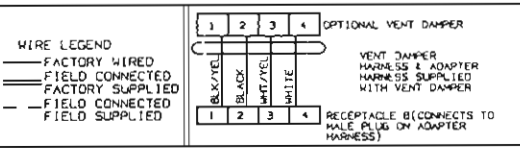
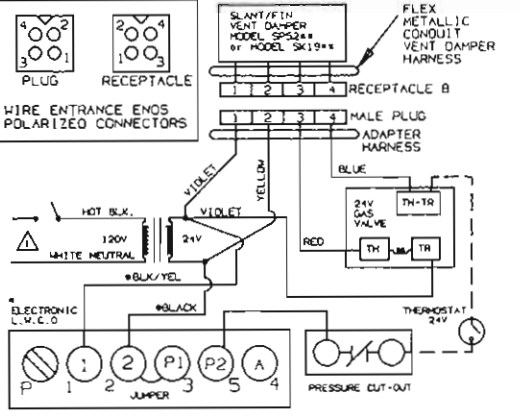

△ PROVIDE DISCONNECT MEANS & OVERLOAD PROTECTION AS REQUIRED.
IF ANY OF THE ORIGINAL WIRE AS SUPPLIED WITH THE APPLIANCE MUST BE REPLACED. IF MUST BE REPLACED WITH TYPE 105° C WIRE OR ITS EQUIVALENT.
* SUMMER/WINTER SWITCH IS ON SK19 V.O. ONLY
** PLUS SUFFIX
* SUMMER/WINTER SWITCH IS SHOWN IN THE WINTER POSITION.
GALAXY/100 SERIES 41-0985

STEAM 24V BOILERS WITH CONTINUOUS PILOT & MM67 L.W.C.O. WITH PROVISION FOR TANKLESS

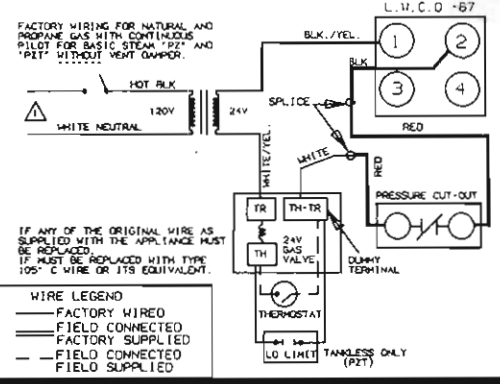

BELOW:
Field Wiring ONLY WITH SLANT/FIN Vent Damper And Continuous Pilot For Basic Steam 'P2' & 'P2T' Models

WARNING
BEFORE INSTALLING OPTIONAL VENT DAMPER READ WARNING LABEL ON THIS BOILER AND VENT DAMPER. READ SLANT/FIN VENT DAMPER INSTALLATION INSTRUCTIONS AND REMOVE ALL EXISTING WIRING FROM BOILER.

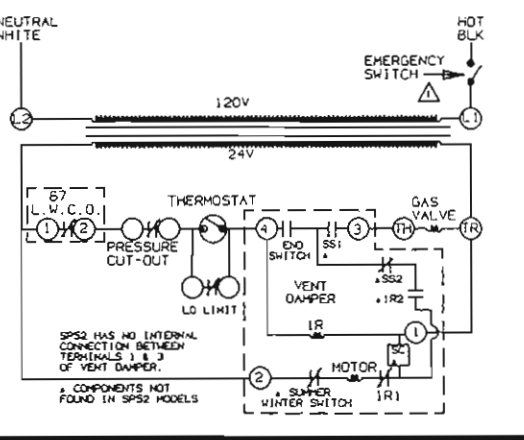
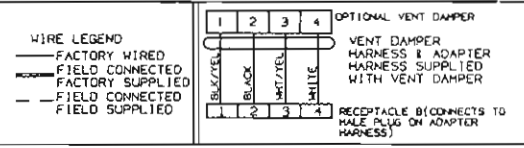
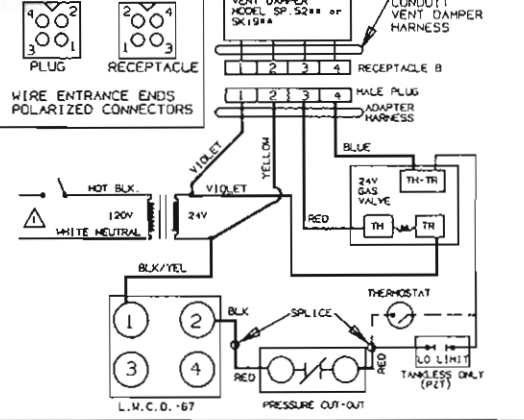

△ PROVIDE DISCONNECT MEANS & OVERLOAD PROTECTION AS REQUIRED.
IF ANY OF THE ORIGINAL WIRE AS SUPPLIED WITH THE APPLIANCE MUST BE REPLACED. IF MUST BE REPLACED WITH TYPE 105° C WIRE OR ITS EQUIVALENT.
** PLUS SUFFIX
* SUMMER/WINTER SWITCH IS SHOWN IN THE WINTER POSITION.
GALAXY/100 SERIES 41-0987

WIRING DIAGRAMS FOR SLANT/FIN GALAXY AND "100" SERIES BASIC HOT WATER BOILER (S OR ST) OR STEAM BOILERS WITH TANKLESS HEATER (PZT), INTERMITTENT PILOT AND WITH OR WITHOUT VENT DAMPER

STEAM 24V INTERMITTENT IGNITION OPTIONAL STEAM/BASIC HOT WATER S86 "S", "ST" AND "PZT" WITH HONEYWELL IGNITION

WARNING
BEFORE INSTALLING OPTIONAL VENT DAMPER READ WARNING LABEL ON THIS BOILER AND VENT DAMPER. READ SLANT/FIN VENT DAMPER INSTALLATION INSTRUCTIONS.

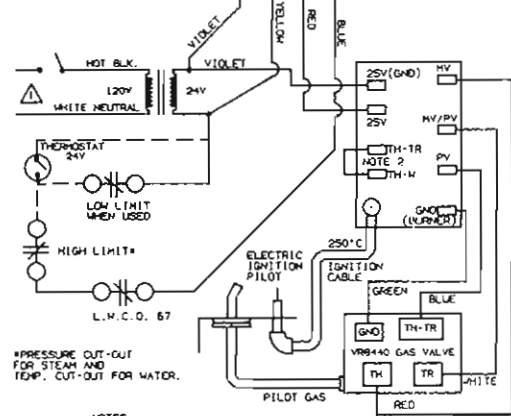
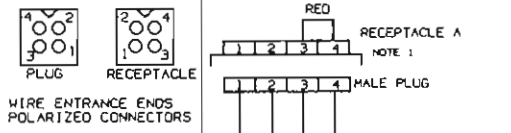
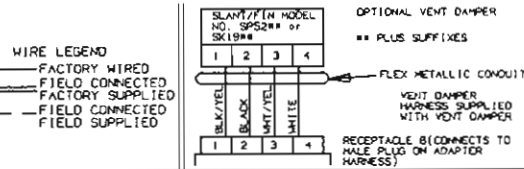

NOTES
1. PLUG IS IN HIGH LIMIT BOX ON "100" SERIES BOILERS.
2. IN LATER S86 MODELS JUMPER & TERMINALS HAVE BEEN ELIMINATED.

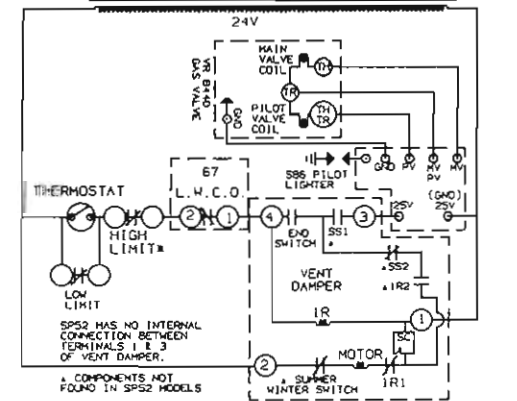
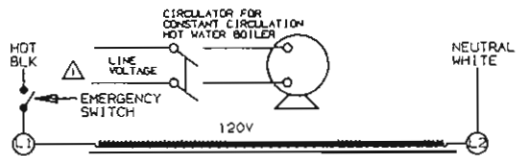

△ PROVIDE DISCONNECT MEANS & OVERLOAD PROTECTION AS REQUIRED.
IF ANY OF THE ORIGINAL WIRE AS SUPPLIED WITH THE APPLIANCE MUST BE REPLACED. IF MUST BE REPLACED WITH TYPE 105° C WIRE OR ITS EQUIVALENT.
** PLUS SUFFIX

△ SUMMER/WINTER SWITCH IS SHOWN IN THE WINTER POSITION.

24V INTERMITTENT IGNITION, VENT DAMPER OPTION, STEAM/BASIC HOT WATER, "S", "ST" AND "PZT" WITH WHITE RODGERS IGNITION

WARNING
BEFORE INSTALLING OPTIONAL VENT DAMPER READ WARNING LABEL ON THIS BOILER AND VENT DAMPER. READ SLANT/FIN VENT DAMPER INSTALLATION INSTRUCTIONS.

24V CONTROL SYSTEM-INTERMITTENT PILOT IGNITION WITH OR WITHOUT VENT DAMPER. STEAM (PZT) AND BASIC HOT WATER (S & ST) BOILERS. NATURAL GAS ONLY.

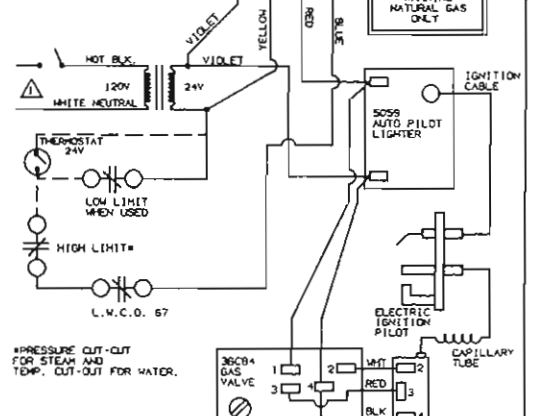
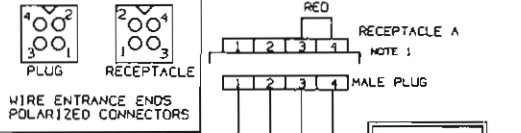
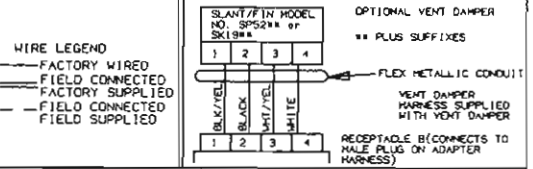

NOTES
1. PLUG IS IN HIGH LIMIT BOX ON "100" SERIES BOILERS.

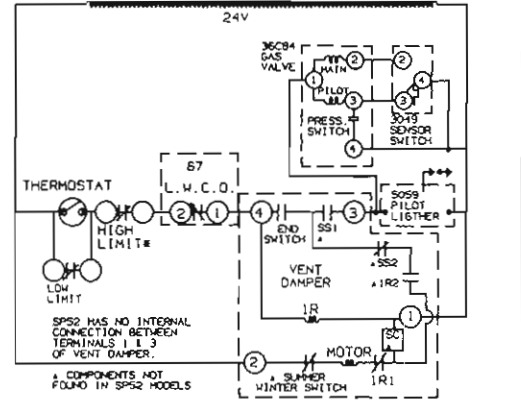
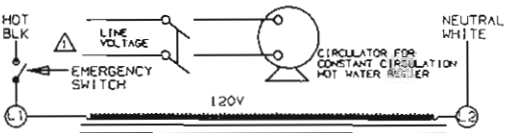

△ PROVIDE DISCONNECT MEANS & OVERLOAD PROTECTION AS REQUIRED.
IF ANY OF THE ORIGINAL WIRE AS SUPPLIED WITH THE APPLIANCE MUST BE REPLACED. IF MUST BE REPLACED WITH TYPE 105° C WIRE OR ITS EQUIVALENT.
** PLUS SUFFIX

△ SUMMER/WINTER SWITCH IS SHOWN IN THE WINTER POSITION.

WARNING
When replacing an S86 F or H replace only with S8600 F or M. For propane use S8600 M only.

WARNING

NOTE:
When replacing an S86 module with an S8600 module, the ignitor cable must also be replaced.

Only 100 Series natural gas boilers can be equipped with VR8204A gas valves.

WIRING DIAGRAMS FOR SLANT/FIN GALAXY STEAM BOILERS
WITHOUT TANKLESS HEATER (PZ), INTERMITTENT PILOT
AND WITH OR WITHOUT VENT DAMPER

STEAM 24V INTERMITTENT IGNITION ELECTRONIC
L.W.C.O. BOILERS WITH HONEYWELL IGNITION
And NO Provision For Tankless

WARNING

BEFORE INSTALLING OPTIONAL VENT DAMPER READ WARNING LABEL ON THIS BOILER AND VENT DAMPER. READ SLANT/FIN VENT DAMPER INSTALLATION INSTRUCTIONS.

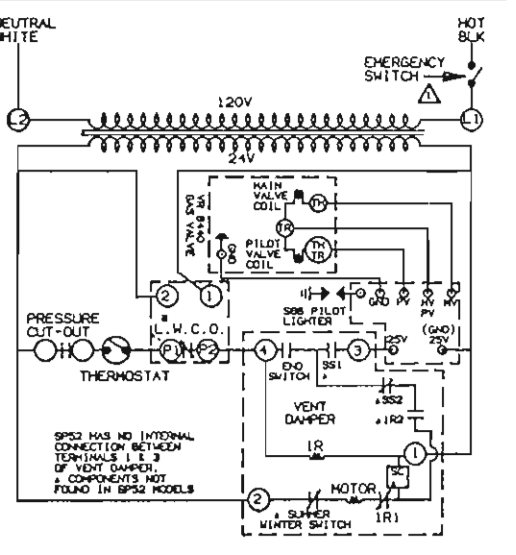
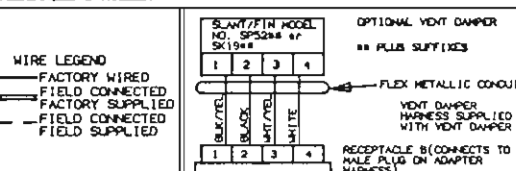
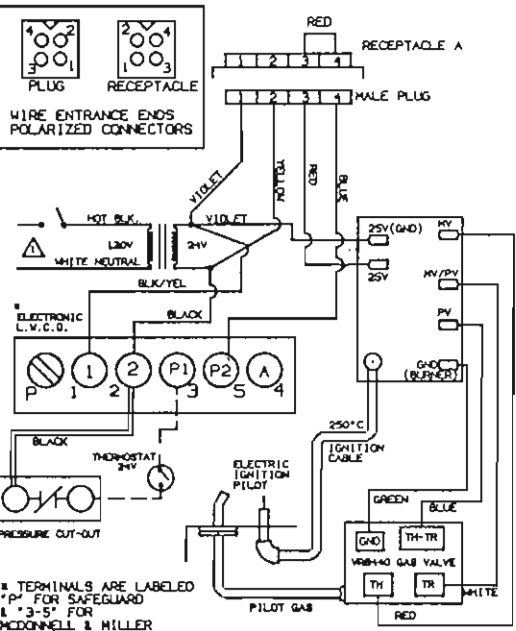

△ PROVIDE DISCONNECT MEANS & OVERLOAD PROTECTION AS REQUIRED.
IF ANY OF THE ORIGINAL WIRE AS SUPPLIED WITH THE APPLIANCE MUST BE REPLACED. IF MUST BE REPLACED WITH TYPE 105° C WIRE OR ITS EQUIVALENT.
** PLUS SUFFIX

▲ SUMMER/WINTER SWITCH IS SHOWN IN THE WINTER POSITION.

STEAM 24V INTERMITTENT IGNITION ELECTRONIC
L.W.C.O. BOILERS WITH WHITE RODGERS IGNITION
And NO Provision For Tankless

WARNING

BEFORE INSTALLING OPTIONAL VENT DAMPER READ WARNING LABEL ON THIS BOILER AND VENT DAMPER. READ SLANT/FIN VENT DAMPER INSTALLATION INSTRUCTIONS.

FACTORY WIRING FOR NATURAL GAS WITH INTERMITTENT IGNITION PILOT FOR STEAM "PZ" MODEL WITH AND WITHOUT VENT DAMPER

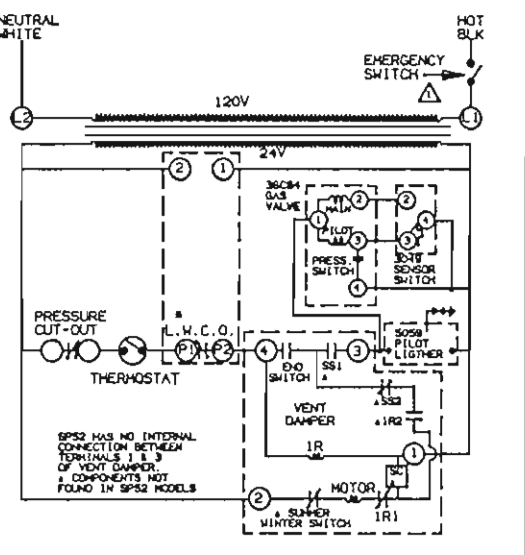
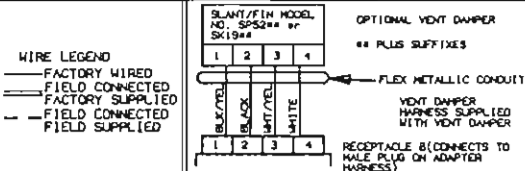
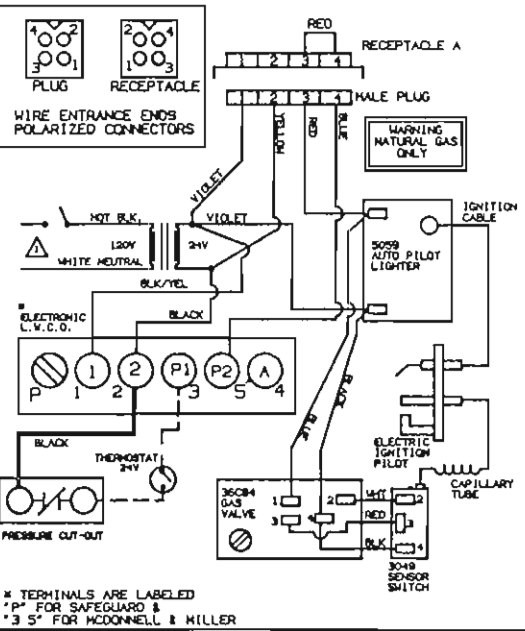

△ PROVIDE DISCONNECT MEANS & OVERLOAD PROTECTION AS REQUIRED.
IF ANY OF THE ORIGINAL WIRE AS SUPPLIED WITH THE APPLIANCE MUST BE REPLACED. IF MUST BE REPLACED WITH TYPE 105° C WIRE OR ITS EQUIVALENT.
** PLUS SUFFIX

▲ SUMMER/WINTER SWITCH IS SHOWN IN THE WINTER POSITION.

WARNING
When replacing an S86 F or H replace only with S8600 F or M. For propane use S8600 M only.

NOTE:
When replacing an S86 module with an S8600 module, the Ignitor cable must also be replaced.

Only 100 Series natural gas boilers can be equipped with VR8204A gas valves.

WIRING DIAGRAMS FOR SLANT/FIN GALAXY AND "100" SERIES
BASIC HOT WATER BOILER (P OR PT) INTERMITTENT PILOT
AND WITH OR WITHOUT VENT DAMPER

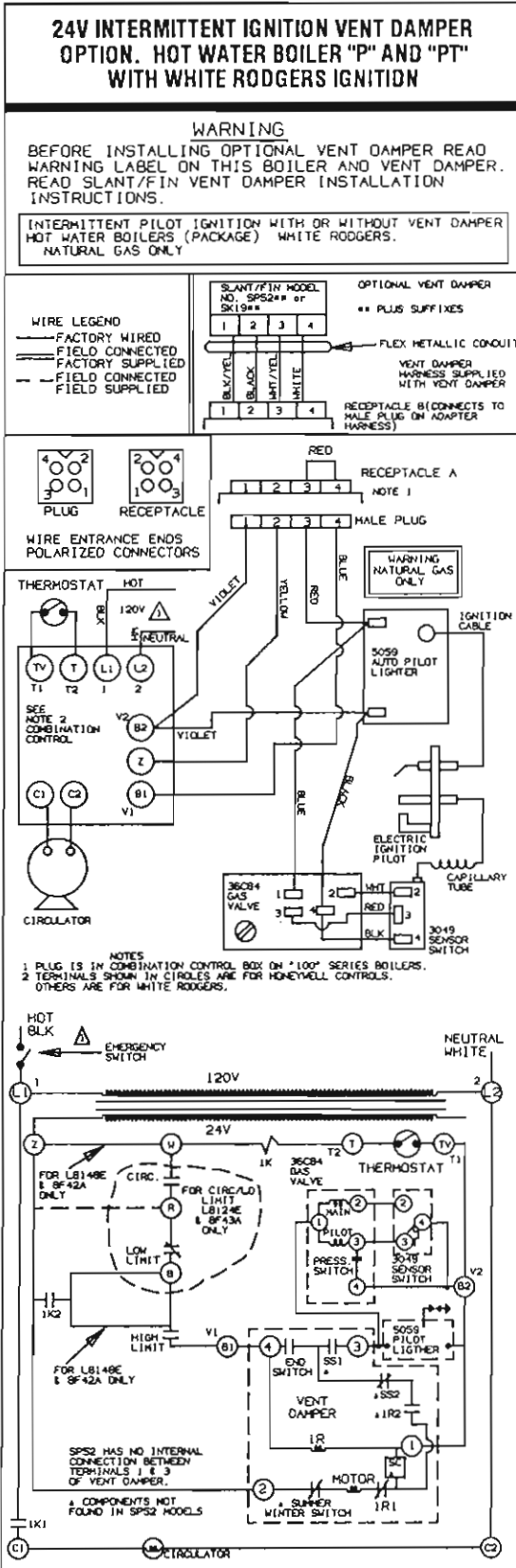

WARNING
When replacing an S86 F or H replace only with S8600 F or M. For propane use S8600 M only.

WARNING
When replacing an S86 module with an S8600 module, the Ignitor cable must also be replaced.

Only 100 Series natural gas boilers can be equipped with VR8204A gas valves.

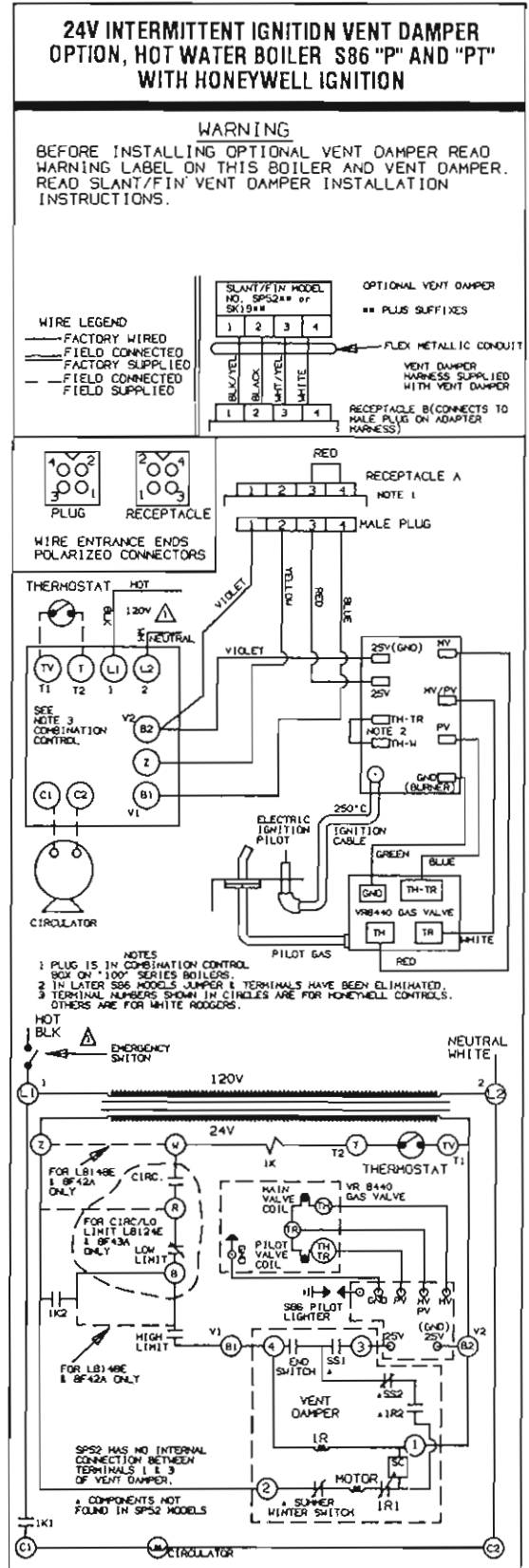

WARNING
PROVIDE DISCONNECT MEANS & OVERLOAD PROTECTION AS REQUIRED.

IF ANY OF THE ORIGINAL WIRE AS SUPPLIED WITH THE APPLIANCE MUST BE REPLACED. IF MUST BE REPLACED WITH TYPE 105° C WIRE OR ITS EQUIVALENT.

** PLUS SUFFIX

Δ SUMMER/WINTER SWITCH IS SHOWN IN THE WINTER POSITION.

PUMP OR VALVE ZONING OF WATER BOILERS COMBINATION CONTROLS WITH T TV Z TERMINALS*

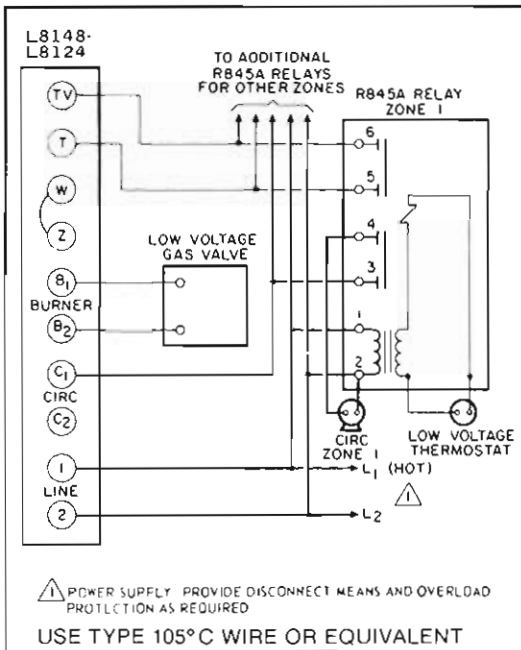

Pump Zoning system using R845 Relay.
One R-845A needed for each circulator.

NOTE: Pumps are powered from (C1). Total pump load must not exceed 7.4 amp rating of combination control pump switch.

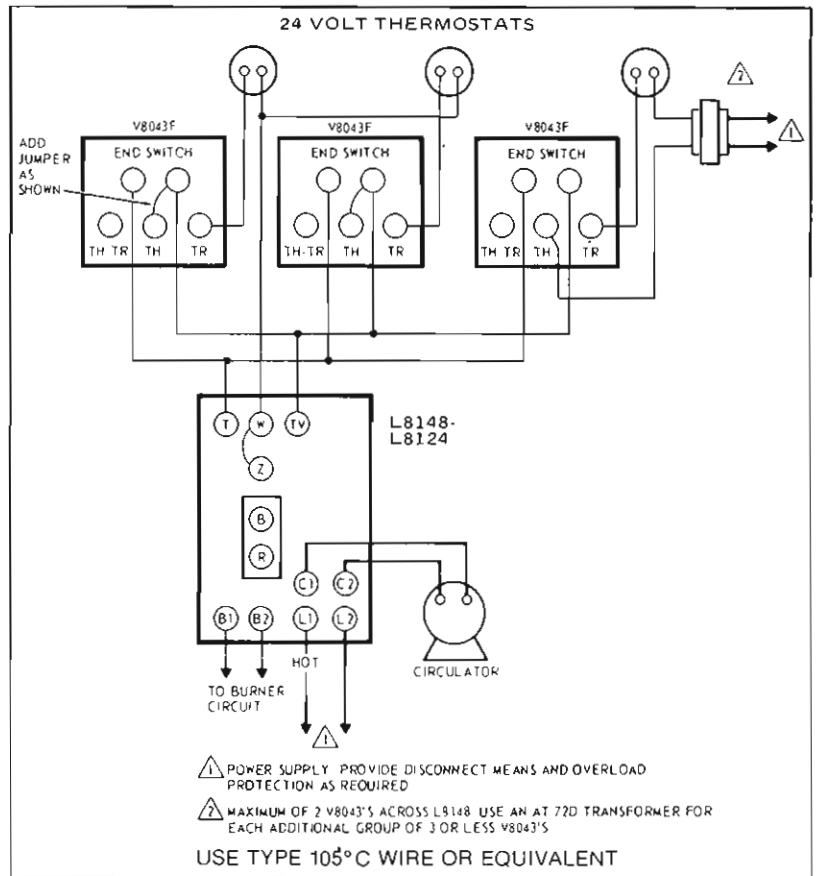

Zone valve zoning system using Honeywell V8043F zone valves.

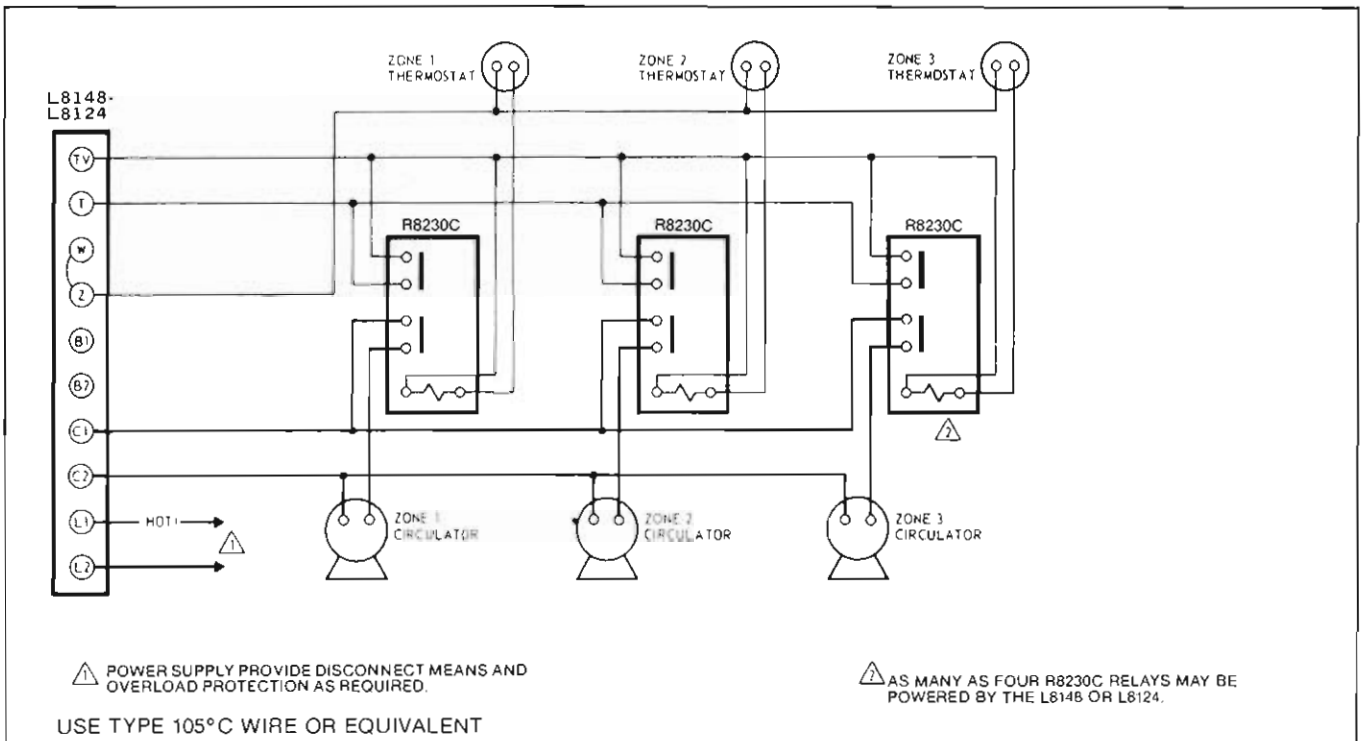

Pump zoning system using R8230C Relays.

*For zoning diagrams, combination controls without T TV Z terminals and non-combination control systems, consult Slant/Fin Zoning Tech. Bulletin.

NOTE: Pumps are powered from (C1). Total pump load must not exceed 7.4 amp rating of combination control pump switch.

BURNERS FAIL TO OPERATE**CAUSE**

1. Safety pilot out, or flame too low.
2. Gas supply valve shut off.
3. Electric switch open.
4. Blown or defective line fuse.
5. Operating or limit control contacts open or dirty.
6. Defective gas valve or pressure regulator; or plugged bleed line.
7. Defective low voltage transformer.
8. Obstruction at main burner orifice.
9. Break in wiring or loose contact at control terminals.
10. Improper Wiring.
11. Improper controls.

REMEDY

1. Check, clean, re-light. See instructions.
2. Open gas valve(s).
3. Close Switch.
4. Replace fuse.
5. Check Control. Clean contacts or replace control.
6. Repair or replace.
7. Replace transformer.
8. Check, clean and reinstall.
9. Check with test-light and correct.
10. Check and correct in accordance with wiring diagrams included with appliance instructions.
11. Install proper controls.

BURNERS WILL NOT SHUT OFF**CAUSE**

1. Defective operating control, gas valve, or high limit control.
2. Improper wiring or short circuit.

REMEDY

1. Check, repair or replace.
2. Check wiring and controls.

FLASH BACK—BURNING AT ORIFICES**CAUSE**

1. Manifold gas pressure too low.
2. Improper primary air adjustment.
3. Gas regulator bleed too slow.
4. Burrs on orifice.
5. Improperly drilled orifice plugs.
6. Leaking automatic gas valve.
7. Adverse draft condition in boiler room.
8. Low main gas pressure.
9. Safety pilot improperly installed.

REMEDY

1. Adjust to proper manifold pressure.
2. Adjust air to produce soft, clean flame.
3. Adjust bleed opening.
4. Remove burrs.
5. Install orifice plugs with proper drilling.
6. Repair or replace.
7. Check air supply and venting system.
8. Contact utility.
9. Correct to manufacturer's recommendations.

DELAYED IGNITION**CAUSE**

1. Pilot flame too low.
2. Pilot burner ports or pilot orifice clogged.
3. Burners or orifices out of alignment.
4. Excessive primary air.
5. Excessive burner input.
6. Adverse draft condition in boiler room.

REMEDY

1. Increase gas supply to pilot.
2. Clean ports or orifices.
3. Re-align burners or manifold.
4. Adjust primary air shutters.
5. Check and reduce to input shown on rating plate.
6. Check air supply and venting system.

FUMES AND GAS ODORS**CAUSE**

1. Leaks in gas piping or accessories.
2. Gas leaks in service line or meter connections.
3. Blocked chimney.
4. Boiler flue-ways blocked with soot.
5. Undersized breeching or too many turns in breeching.
6. Adverse draft condition in boiler room.
7. Overfiring.

REMEDY

1. Locate leaks and repair.
2. Close service supply valve—shut down appliance and notify utility.
3. Check and repair chimney.
4. Clean flue-ways and adjust burners as described in the installation instructions.
5. Check manufacturer's recommendations.
6. Check air supply and venting system.
7. Adjust gas input to that shown on boiler rating plate.

CONDENSATION IN BOILER FLUES OR IN VENT SYSTEM**CAUSE**

1. Underfiring.
2. Boiler water maintained at too low a temperature level.
3. Long horizontal run of smokepipe.
4. Inadequate chimney or venting system.

REMEDY

1. Increase firing rate to that shown on rating plate.
2. Set low limit controls to maintain a higher water temperature. If boiler is not equipped with low limit replace with one which has a combination low limit/high limit aquastat.
3. Relocate boiler or insulate breeching.
4. Check chimney and venting recommendations.

PIPING A HEATING — COOLING SYSTEM TO A WATER BOILER AND CHILLER

Figure below illustrates a method of piping a heating-cooling system to a water boiler and a chiller. Hand valves (shown) or automatic valves must be installed to prevent circulation of chilled water in the boiler or hot water in the chiller.

The air control system and pressure control system must operate with chiller, only, or the boiler, only, being valved to the piping system. Separate control devices on the boiler and chiller may be used, or a single set of air and pressure controls on the common piping may be preferred.

If the boiler is used to supply hot water to heating coils in air handling units, flow control valves or other devices must be installed to prevent gravity circulation of water in the coils during the cooling cycle.

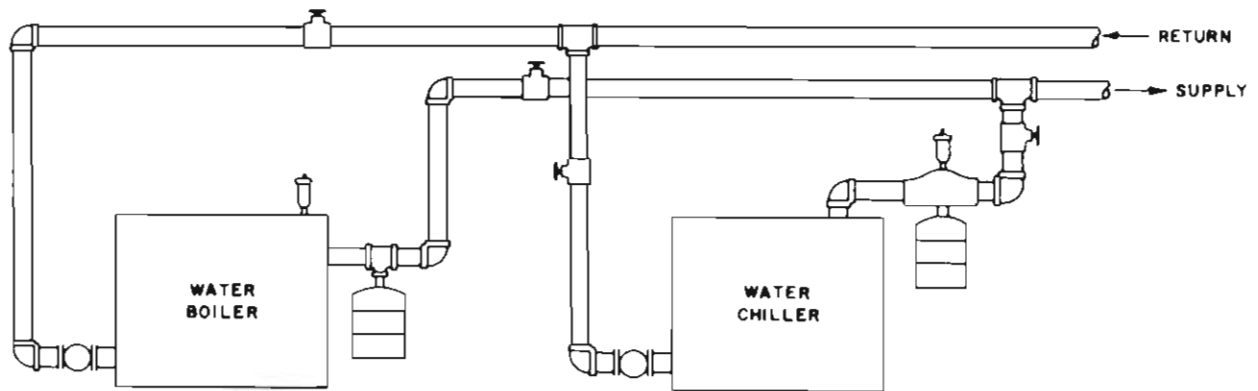

IF REPLACEMENT PARTS ARE NEEDED

When parts are needed, refer to boiler model and serial number shown on the boiler name/rating plate. Refer to the following parts lists for part numbers, publication number GG-10 PL for Galaxy GG Series, GX-10 PL for Galaxy GX Series and 100-10 PL for Reliant 100A Series boilers. Whenever possible refer to the original order by number and date.

Control identification and replacement should not be attempted by unskilled personnel. Only simple, easily-identified controls and parts may be obtained locally. All other controls and parts should be identified by and ordered from Slant/Fin. Relief/Safety valves must be ASME rated for the pressure and gross output of the boiler.

Replacement parts are available from:

Slant/Fin Corp.
100 Forest Drive
Greenvale, NY 11548
Attn: Tech. Service Dept.